

Effective pressure
detection via damper blade



Compact controller with
display



Tested to VDI 6022

VAV terminal units

TVE

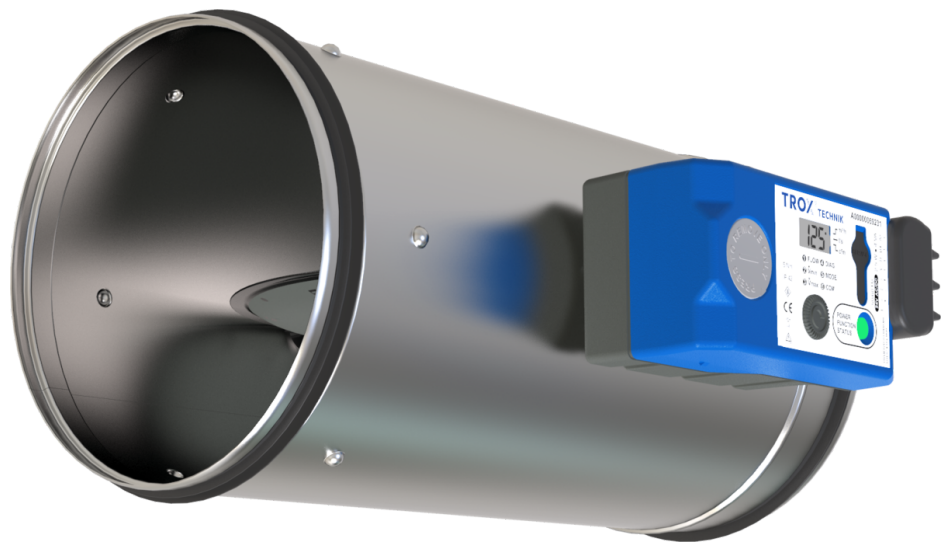

Compact solution for low airflow velocities

Circular air terminal unit for use in variable air volume systems at low airflow velocities even under unfavourable upstream conditions

- Effective tubeless pressure monitoring via damper blade
- Effective pressure transmission through pressure channel in shaft
- Terminals with protective cover – no junction boxes required
- Any direction of flow with dynamic transducer
- Suitable for airflow velocity of 0.5 – 13 m/s
- Compact dimensions for use in confined ceiling areas
- Plug-and-play solution in conjunction with X-AIRCONTROL room control
- Exact measurement even at low airflow velocities
- Any installation orientation even with static transducers
- Closed blade air leakage tested to EN 1751, at least class 3
- Casing air leakage tested to EN 1751, class C
- Volume flow rate range 1:25

Optional equipment and accessories

- Acoustic cladding for the reduction of case-radiated noise
- Secondary silencer Type CA, CS or CF for the reduction of air-regenerated noise
- Hot water heat exchanger Type WL and electric air heater Type EL for reheating the airflow

General information	2	Order code	9
Function	4	Variants	11
Technical data	5	Dimensions	13
Quick sizing	6	Product details	16
Specification text	7	Explanation	18

General information

Application

- Circular VARYCONTROL VAV terminal unit for use in room air conditioning systems (HVAC systems)
- Also for unfavourable upstream conditions at low airflow velocities for supply air or exhaust air flow control in variable air volume systems
- Closed-loop volume flow control using an external power supply
- For controlling, restricting, or shutting off the airflow in air conditioning systems
- Shut-off by means of switching (equipment supplied by others)

Special characteristics

- Highly effective pressure signal at a small angle of attack
- Factory set-up or programming and aerodynamic function testing
- Volume flow rate can be measured and subsequently adjusted on site; additional adjustment tool may be necessary (depending on the variant of the control component)
- Effective tubeless pressure monitoring via damper blade
- Effective pressure transmission through pressure channel in shaft
- Suitable for any flow direction due to dynamic transducer
- Any installation orientation even with static transducers
- Suitable for airflow velocity of 0.5 – 13 m/s
- Compact dimensions for use in confined ceiling areas

Nominal sizes

- 100, 125, 160, 200, 250

Variants

- TVE: VAV terminal unit
- TVE-D: VAV terminal unit with acoustic cladding
- TVE-FL: VAV terminal unit with flanges on both ends
- TVE-D-FL: VAV terminal unit with acoustic cladding and flanges on both ends
- Unit with acoustic cladding and/or a secondary silencer Type CA, CS or CF for demanding acoustic requirements

Construction

- Galvanised sheet steel
- P1: Powder-coated, silver grey (RAL 7001)
- A2: Stainless steel

Parts and characteristics

- Ready-to-commission unit which consists of mechanical parts and control components.
- Damper blade with integrated measuring unit
- Shaft with effective pressure channel for measured value transmission
- Factory assembled control components complete with wiring
- Aerodynamic functional testing on a special test rig prior to shipping of each unit
- Set-up data is given on a label or volume flow rate scale affixed to the unit

- High control accuracy even in the case of unfavourable upstream conditions

Attachments

- EASY controller: Compact unit consisting of controller with potentiometers, effective pressure transducer and actuator
- Compact controller: Compact unit consisting of controller with potentiometers, effective pressure transducer and actuator
- Compact controller Modbus: variant with Modbus RTU interface; Plug-and-play solution in conjunction with X-AIRCONTROL room control

Accessories

- G2: Matching flanges for both ends
- D2: Double lip seals on both ends (factory fitted)

Useful additions

- Secondary silencer Type CA, CS or CF for demanding acoustic requirements
- Heat exchanger Type WL
- Electric air heater Type EL

Construction features

- Circular casing
- Spigot suitable for circular ducts to EN 1506 or EN 13180
- Spigot with groove for double lip seal
- Position of the damper blade indicated externally at position indicator
- TVE-FL: Flanges to EN 12220
- Control component can be replaced

Materials and surfaces

Galvanised sheet steel construction

- Casing made of galvanised sheet steel
- Control damper blade, effective pressure sensor and shaft made of plastic, PA6, UL94, flame retardant (V-0)
- Damper blade seal made of plastic, TPU, microbacterial resistant
- Plastic bearings

Powder-coated construction (P1)

- Casing made of galvanised sheet steel, surface powder coated, silver grey (RAL 7001)
- Control damper blade, effective pressure sensor and shaft made of plastic, PA6, UL94, flame retardant (V-0)
- Damper blade seal made of plastic, TPU, microbacterial resistant
- Plastic bearings

Stainless steel construction (A2)

- Casing made of stainless steel 1.4301
- Control damper blade, effective pressure sensor and shaft made of plastic, PA6, UL94, flame retardant (V-0)
- Damper blade seal made of plastic, TPU, microbacterial resistant
- Plastic bearings

Acoustic cladding

- Variant with acoustic cladding (-D)
- Acoustic cladding made of galvanised sheet steel
- Rubber profile for the insulation of structure-borne noise

- Lining is mineral wool

Mineral wool

- Tested to EN 13501, fire rating class A1, non-combustible
- RAL quality mark RAL-GZ 388
- Biosoluble and hence hygienically safe according to the German TRGS 905 (Technical Rules for Hazardous Substances) and EU directive 97/69/EC

Standards and guidelines

- Hygiene conforms to VDI 6022
- Casing air leakage tested to EN 1751, class C

Closed blade air leakage:

NW 100 – 160

- EN 1751, Class 3
- Meets the general requirements of DIN 1946, part 4, with regard to the acceptable closed blade air leakage

NW 200 – 250

- EN 1751, Class 4
- Meets the increased requirements of DIN 1946, part 4, with regard to the acceptable closed blade air leakage

Maintenance

- Maintenance-free as construction and materials are not subject to wear

Function

Functional description

The control damper blade works as an actuator and as an effective pressure sensor. Through the effective pressure channel in the shaft of the detected effective pressure reaches the transducer (static or dynamic), is converted into an electrical signal and compared with the setpoint value.

In the case of a control deviation, the integrated actuator changes the position of the control damper blade. As a result, the volume flow rate is kept constant in close tolerances over the entire differential pressure range.

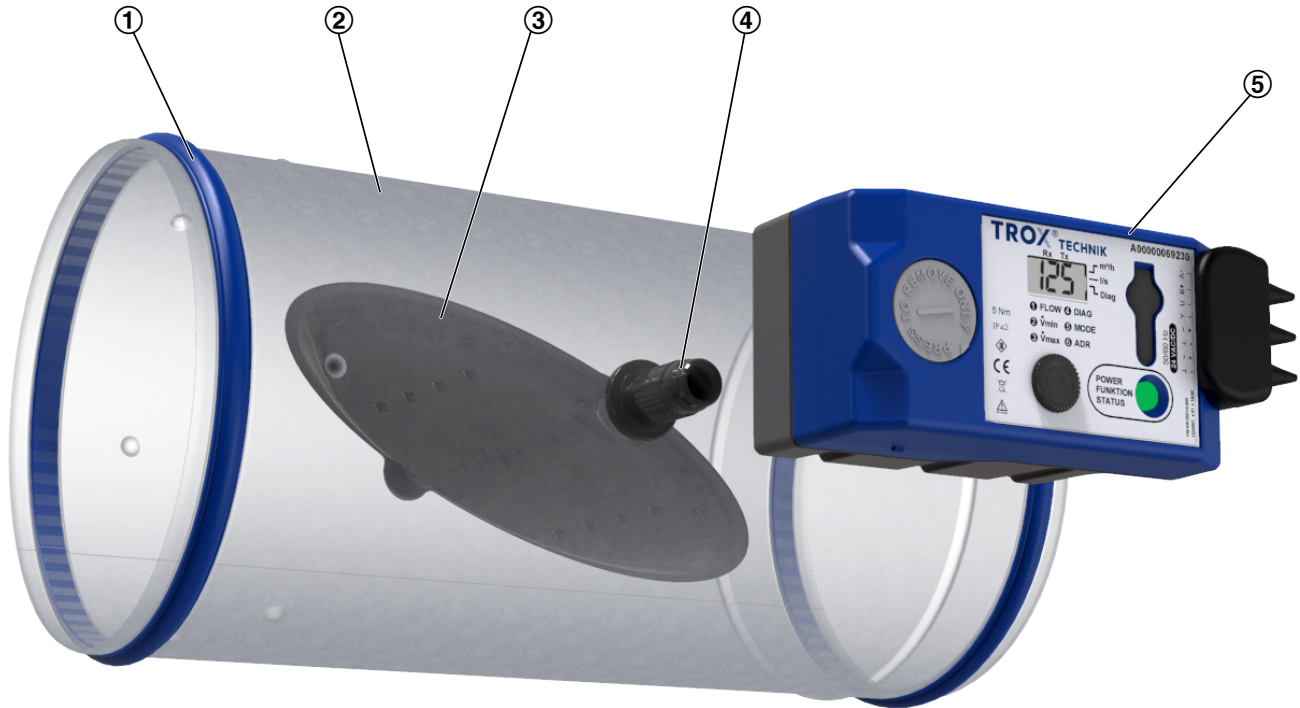

- ① Double lip seal
- ② Casing
- ③ Damper blade including effective pressure sensor

- ④ Shaft with effective pressure channel
- ⑤ Electronic volume flow controller

Technical data

Nominal sizes	100 – 250 mm
Volume flow rate range	4 – 637 l/s or 14 – 2293 m ³ /h
Volume flow rate control range (unit with dynamic effective pressure measurement)	Approx. 4 to 100 % of the nominal volume flow rate
Minimum differential pressure	<5 – 82 Pa
Maximum differential pressure	Control component with dynamic transducer: 900 Pa, Control component with static transducer: 600 Pa
Operating temperature	10 to 50 °C

Volume flow rate ranges and minimum differential pressures

NS	qv [l/s]	qv [m ³ /h]	Static differential pressure, minimum [Pa]				Δqv [±%]
			①	②	③	④	
100	4	14	<5	<5	<5	<5	18
100	35	127	11	<5	<5	6	7
100	67	241	38	8	15	23	5
100	98	354	82	16	33	49	5
125	6	21	<5	<5	<5	<5	19
125	58	207	9	<5	<5	5	7
125	109	393	32	6	12	18	5
125	161	579	69	13	26	40	5
160	10	35	<5	<5	<5	<5	18
160	93	333	6	<5	<5	<5	7
160	175	631	21	<5	8	12	5
160	258	929	45	9	18	27	5
200	15	55	<5	<5	<5	<5	18
200	150	541	<5	<5	<5	<5	7
200	285	1027	18	<5	7	10	5
200	420	1513	38	7	15	22	5
250	24	87	<5	<5	<5	<5	18
250	228	822	<5	<5	<5	<5	7
250	433	1558	13	<5	<5	7	5
250	637	2293	28	5	10	16	5

① TVE, Δ_{pstmin}

② TVE, Δ_{pstmin} with secondary silencer CS/CF, insulation thickness 50 mm, length 500 mm

③ TVE, Δ_{pstmin} with secondary silencer CS/CF, insulation thickness 50 mm, length 1000 mm

④ TVE, Δ_{pstmin} with secondary silencer CS/CF, insulation thickness 50 mm, length 1500 mm

Quick sizing

Quick sizing tables provide a good overview of the room sound pressure levels that can be expected. Approximate intermediate values can be interpolated. Precise intermediate values and spectral data can be calculated with our Easy Product Finder design programme.

The first selection criteria for the nominal size are the actual volume flow rates q_{vmin} and q_{vmax} . The quick sizing tables are based on generally accepted attenuation levels. If the sound pressure level exceeds the required level, a larger air terminal unit and/or a silencer is required.

TVE, sound pressure level at differential pressure 150 Pa

NS	qv [l/s]	qv [m³/h]	Air-regenerated noise [dB(A)]				Case-radiated noise	
			①	②	③	④	⑤	⑥
100	4	14	28	17	<15	<15	<15	15
100	35	127	45	31	26	23	28	17
100	67	241	50	34	29	26	33	22
100	98	354	53	36	31	27	36	25
125	6	21	26	<15	<15	<15	<15	<15
125	58	207	45	33	29	25	28	17
125	109	393	50	40	36	33	33	22
125	161	579	53	43	39	36	37	26
160	10	35	37	28	23	19	17	<15
160	93	333	48	38	34	30	28	21
160	175	631	50	40	36	32	31	24
160	258	929	50	40	36	33	33	26
200	15	55	27	<15	<15	<15	<15	<15
200	150	541	46	35	30	27	26	<15
200	285	1027	48	38	34	31	31	16
200	420	1513	50	40	36	33	35	20
250	24	87	35	25	18	<15	19	<15
250	228	822	47	40	36	34	33	18
250	433	1558	48	42	39	37	38	23
250	637	2293	49	44	41	39	40	25

① TVE, L_{PA}

② TVE, L_{PA1} , with secondary silencer CS/CF, insulation thickness 50 mm, length 500 mm

③ TVE, L_{PA1} , with secondary silencer CS/CF, insulation thickness 50 mm, length 1000 mm

④ TVE, L_{PA1} , with secondary silencer CS/CF, insulation thickness 50 mm, length 1500 mm

⑤ TVE, L_{PA2}

⑥ TVE-D, L_{PA3}

The sound power levels for calculating the sound pressure levels were measured in the TROX laboratory according to DIN EN ISO 5135 - see "Basic information and nomenclature".

Specification text

This specification text describes the general properties of the product. Texts for variants can be generated with our Easy Product Finder design programme.

Specification text

Circular VAV terminal units for variable and constant air volume systems, suitable for supply or extract air, available in five nominal sizes. High control accuracy even in case of unfavourable upstream conditions. Control range at least 1:25. Differential pressure detection and control via the control damper blade. Transmission of effective pressure tubeless through differential pressure channel in the shaft. Closed blade air leakage to EN 1751: at least class 3, from NS 200: class 4. Casing air leakage to EN 1751, class C. Ready-to-commission unit which consists of the mechanical parts and the factory installed electronic control component. Position of the damper blade can be seen from the outside on the control component. Damper blade is factory set to open position which allows ventilation airflow even without control.

Special characteristics

- Highly effective pressure signal at a small angle of attack
- Factory set-up or programming and aerodynamic function testing
- Volume flow rate can be measured and subsequently adjusted on site; additional adjustment tool may be necessary (depending on the variant of the control component)
- Effective tubeless pressure monitoring via damper blade
- Effective pressure transmission through pressure channel in shaft
- Suitable for any flow direction due to dynamic transducer
- Any installation orientation even with static transducers
- Suitable for airflow velocity of 0.5 – 13 m/s
- Compact dimensions for use in confined ceiling areas

Materials and surfaces

Galvanised sheet steel construction

- Casing made of galvanised sheet steel
- Control damper blade, effective pressure sensor and shaft made of plastic, PA6, UL94, flame retardant (V-0)
- Damper blade seal made of plastic, TPU, microbacterial resistant
- Plastic bearings

Powder-coated construction (P1)

- Casing made of galvanised sheet steel, surface powder coated, silver grey (RAL 7001)
- Control damper blade, effective pressure sensor and shaft made of plastic, PA6, UL94, flame retardant (V-0)
- Damper blade seal made of plastic, TPU, microbacterial resistant
- Plastic bearings

Stainless steel construction (A2)

- Casing made of stainless steel 1.4301

- Control damper blade, effective pressure sensor and shaft made of plastic, PA6, UL94, flame retardant (V-0)
- Damper blade seal made of plastic, TPU, microbacterial resistant
- Plastic bearings

Acoustic cladding

- Variant with acoustic cladding (-D)
- Acoustic cladding made of galvanised sheet steel
- Rubber profile for the insulation of structure-borne noise
- Lining is mineral wool

Mineral wool

- Tested to EN 13501, fire rating class A1, non-combustible
- RAL quality mark RAL-GZ 388
- Biosoluble and hence hygienically safe according to the German TRGS 905 (Technical Rules for Hazardous Substances) and EU directive 97/69/EC

Construction

- Galvanised sheet steel
- P1: Powder-coated, silver grey (RAL 7001)
- A2: Stainless steel

Technical data

- Minimum differential pressure: 5 – 82 Pa

Maximum differential pressure

- Control component with dynamic transducer: 900 Pa
- Control component with static transducer: 600 Pa

Specification text attachment

Variable volume flow control with electronic Easy controller to connect an external control signal; actual value signal can be integrated into the central BMS.

- 24 V AC/DC supply voltage
- Signal voltages 0 – 10 V DC
- Possible override controls with external switches using volt-free contacts: CLOSED, OPEN, $q_{v_{min}}$ and $q_{v_{max}}$
- Potentiometers with percentage scales to set the volume flow rates $q_{v_{min}}$ and $q_{v_{max}}$
- The actual value signal relates to the nominal volume flow rate such that commissioning and subsequent adjustment are simplified
- Volume flow rate control range: approx. 4 – 100 % of the nominal volume flow rate
- From the outside well visible indicator light for signalling the various operating conditions

Electrical connections with screw terminals. Double terminals for looping the supply voltage, i.e. for the simple connection of voltage transmission to the next controller.

Sizing data

- q_v _____ [m³/h]
- Δ_{pst} _____ [Pa]

Case-radiated noise

- L_{PA} _____ [dB(A)]

Air-regenerated noise

- L_{PA} _____ [dB(A)]

Order code

TVE - D - P1 - FL / 100 / D2 / XB0 / V 0 / 200 - 900 m³/h
 | | | | | | | | | | |
 1 2 3 4 5 6 7 8 9 10 11

1 Type

TVE Volume flow controller, circular

2 Acoustic cladding

No entry: none

D With acoustic cladding

3 Material (not Easy)

No entry: galvanised sheet steel

P1 Duct powder-coated, RAL 7001, silver grey

A2 Duct made of stainless steel

4 Duct interface (not Easy)

No entry: Insert with groove for double lip seal for duct to EN1506

FL Flanges on both ends

5 Nominal size [mm]

100, 125, 160, 200, 250

6 Accessories

No entry: none

D2 Double lip seal both sides (only with insertion with groove)

G2 Matching flange to each flange (only with FL)

7 Attachment (control component)

Easy Volume flow controller, dynamic, interface analog, setting q_{vmin} and q_{vmax} with potentiometers

XB0 Volume flow controller, dynamic, interface analogue

XM0 Volume flow controller, analogue interface and Modbus RTU, display

XM0-J6 Volume flow controller, analogue and Modbus RTU interface, display, RJ12 socket (for X-AIRCONTROL)

XS0 Volume flow controller, static, interface analogue and Modbus RTU, display

XS0-J6 Volume flow controller, static, interface analogue and Modbus RTU, display, RJ12 socket (for X-AIRCONTROL)

8 Operating mode (not Easy)

V Variable, setpoint value range (not for XM0-J6, XS0-J6)

F Constant value, a setpoint value (not for XM0-J6, XS0-J6)

M Modbus RTU interface (only selectable with XM0, XS0 attachment, mandatory for XM0-J6, XS0-J6)

9 Signal voltage range (not with Easy, operating mode M)

0 0 – 10V DC

2 2 – 10V DC

10 Operating values for factory setting (not for Easy)

Volume flow rates in [m³/h or l/s] see unit

q_{vconst} (in operating mode F)

$q_{vmin-qvmax}$ (in operating mode V, M)

11 Unit (not Easy)

m³/h Volume flow rates in m³/h

l/s Volume flow rates in l/s

Order example: TVE/200/D2/XB0/V0/500–1200 m³/h

Acoustic cladding

Without

Material

Galvanised sheet steel

Flange

Without

Nominal size

200 mm

Accessories

Double lip seal both sides

Attachment

Compact controller

Operating mode

Variable

Signal voltage range

0 – 10V DC

Volume flow rate

500 – 1200 m³/h

TVE – D / 200 / D2 / Easy
| | | | |
1 2 5 6 7

1 Type

TVE VAV terminal unit

2 Acoustic cladding

No entry: none

D With acoustic cladding**5 Nominal size [mm]**

100, 125, 160, 200, 250

Order example: TVE-D/125/D2/Easy**Acoustic cladding****Material****Nominal size****Accessories****Attachment****6 Accessories**

No entry: none

D2 Double lip seal both sides**7 Attachments (control components)****Easy** Easy controller

With

Galvanised sheet steel

200 mm

Double lip seal both sides

Easy controller

Variants

VAV terminal unit, variant TVE

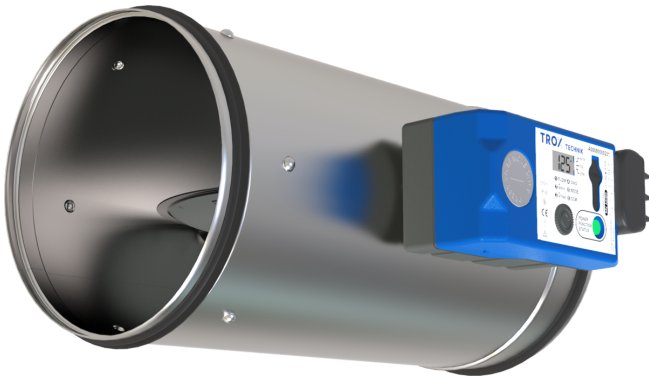

Application

- VAV terminal unit for variable volume flow control
 - Spigot
-

VAV terminal unit, variant TVE-D

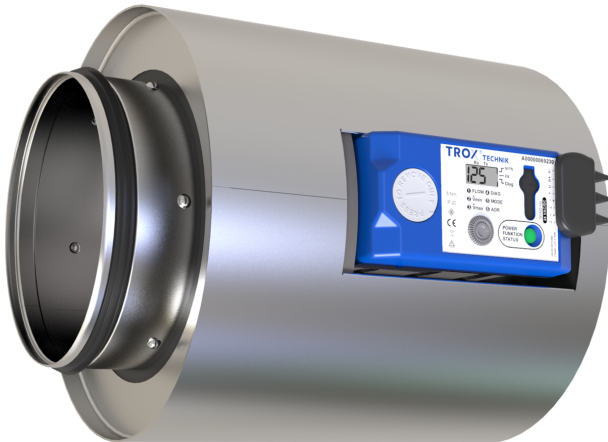

Application

- Air terminal unit with acoustic cladding for variable volume flow control
 - For rooms where the case-radiated noise of the unit is not sufficiently reduced by a false ceiling
 - The circular ducts for the room under consideration must have adequate acoustic insulation (provided by others) on the fan and room ends
 - Acoustic cladding cannot be retrofitted
-

VAV terminal unit, variant TVE-FL

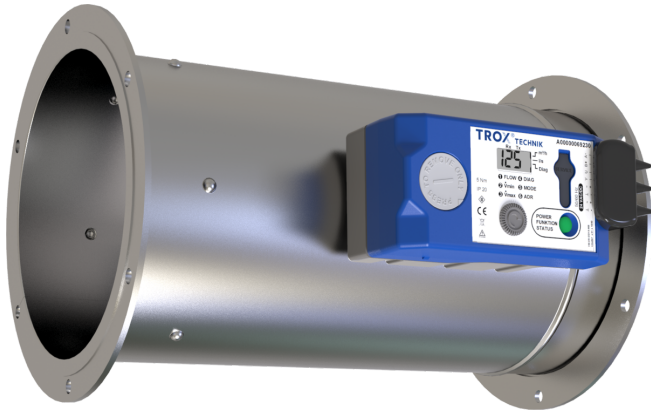

Application

- VAV terminal unit for variable volume flow control
- With flanges on both ends to make detachable connections to the ducting
- Optional available with matching flanges

VAV terminal unit, variant TVE-D-FL

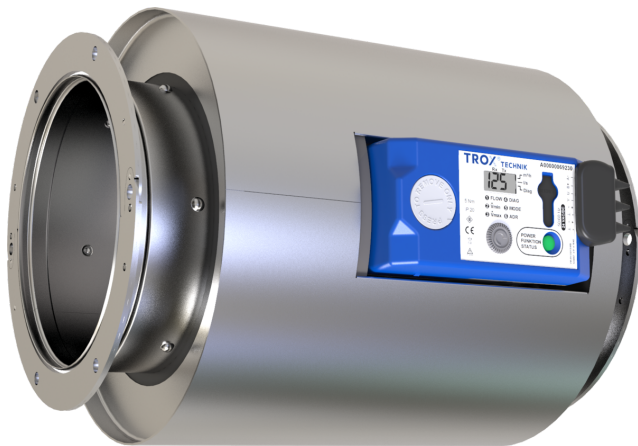

Application

- Air terminal unit with acoustic cladding for variable volume flow control
- With flanges on both ends to make detachable connections to the ducting
- Optional available with matching flanges
- For rooms where the case-radiated noise of the unit is not sufficiently reduced by a false ceiling
- The circular ducts for the room under consideration must have adequate acoustic insulation (provided by others) on the fan and room ends
- Acoustic cladding cannot be retrofitted

Dimensions

TVE

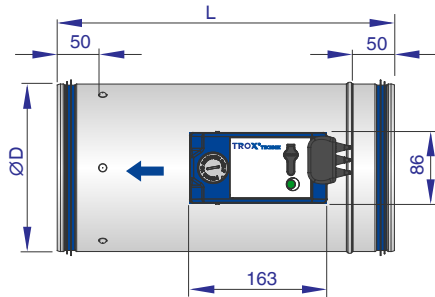

TVE

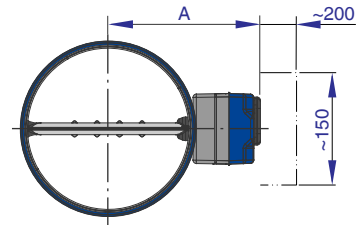

Product specific data TVE

NS	L	A	ØD	kg
100	310	135	99	3,3
125	310	148	124	3,6
160	400	165	159	4,2
200	400	185	199	5,1
250	400	210	249	6,1

TVE-D

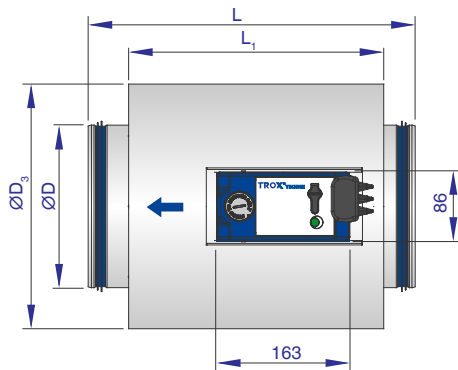

TVE-D

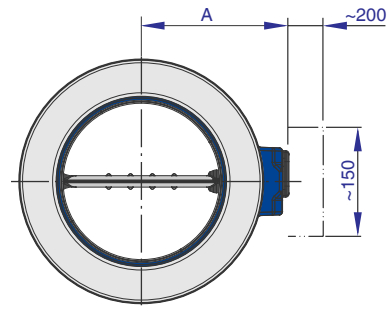

Product specific data TVE-D

NS	L	L ₁	A	ØD	ØD ₃	kg
100	310	232	135	99	198	7,2
125	310	232	148	124	223	8,5
160	400	312	165	159	258	11
200	400	312	185	199	298	12,9
250	400	312	210	249	348	15,9

TVE-FL

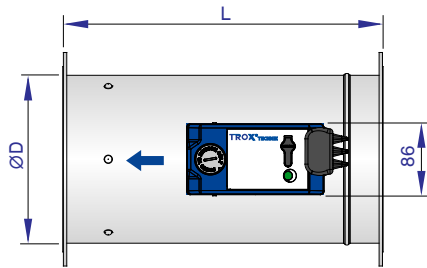

TVE-FL

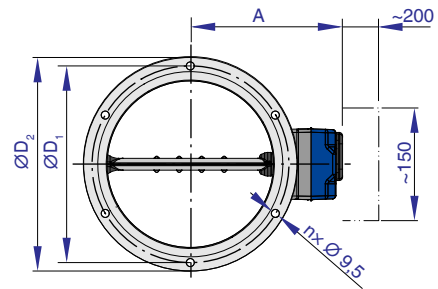

Product specific data TVE-FL

NS	L	A	ØD	ØD ₁	ØD ₂	n	D	kg
100	290	135	99	132	152	4	4	3,9
125	290	148	124	157	177	4	4	4,2
160	380	165	159	192	212	6	4	5,3
200	380	185	199	233	253	6	4	6,5
250	380	210	249	283	303	6	4	7,8

TVE-D-FL

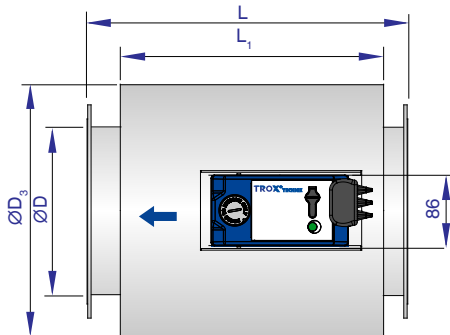

TVE-D-FL

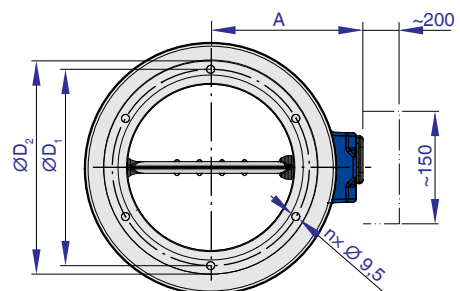

Product specific data TVE-D-FL

NS	L	L ₁	A	ØD	ØD ₁	ØD ₂	ØD ₃	n	D	kg
100	290	232	135	99	132	152	198	4	4	7,8
125	290	232	148	124	157	177	223	4	4	9,1
160	380	312	165	159	192	212	258	6	4	12,1
200	380	312	185	199	233	253	298	6	4	14,3
250	380	312	210	249	283	303	348	6	4	17,6

Access to attachments, mounted on one side

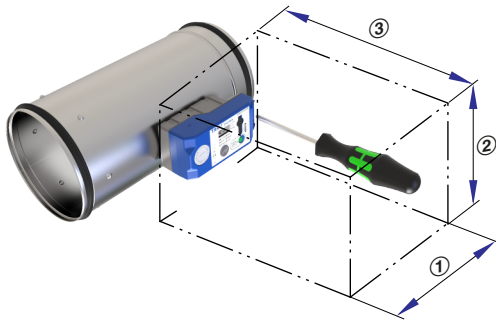

Space requirement, control component on one side

Attachments	①	②	③
Easy controller	250	200	300
Compact controller	250	200	300

Space required for commissioning and maintenance

Sufficient space must be kept clear near any attachments to allow for commissioning and maintenance. It may be necessary to provide sufficiently sized inspection access openings.

Product details

Installation and commissioning

- Any installation orientation
- TVE-D: For constructions with acoustic cladding, ducts on the room side should have cladding up to the acoustic cladding of the controller

Upstream conditions

The effective pressure, which is decisive for the volume flow rate, is recorded and averaged on the control damper blade.

Therefore, the volume flow rate accuracy Δq_v is independent of the upstream section.

Duct connections, e.g. branches off the main duct, must comply with EN 1506 and EN 13180.

Bend

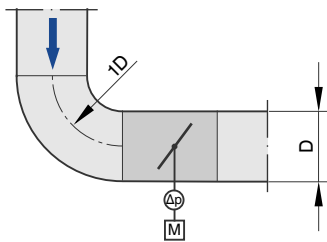

A bend without a straight duct section upstream of the VAV terminal unit – has only a negligible effect on the volume flow rate accuracy.

Junction

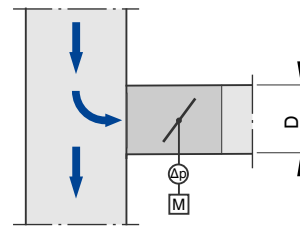

No upstream section required.

A junction causes strong turbulence. The stated volume flow rate accuracy q_v can be achieved without upstream section.

TVE control components VARYCONTROL

Attachment	Controlled variable	Category, Interface, Characteristics	Differential pressure transmitter	Actuator
Easy	qv	Easy controller	Dynamic integrated	integrated
XB0	qv	Compact controller	Dynamic integrated	integrated
XM0	qv	Compact controller Analogue and Modbus RTU Display	Dynamic integrated	integrated
XM0-J6	qv	Compact controller Analogue and Modbus RTU with RJ12 socket Display	Dynamic integrated	integrated
XS0	qv	Compact controller Analogue and Modbus RTU Display	Static integrated	integrated
XS0-J6	qv	Compact controller Analogue and Modbus RTU with RJ12 socket Display	Static integrated	integrated

 q_v Volume flow rate

Explanation

<p>NS [mm] Nominal size</p> <p>ØD [mm] Control units made of sheet steel: Outer diameter of the spigot, control units made of plastic: Inside diameter of the spigot</p> <p>ØD₁ [mm] Pitch circle diameter of flanges</p> <p>ØD₂ [mm] Outer diameter of flanges</p> <p>ØD₄ [mm] Inside diameter of the screw holes of flanges</p> <p>L [mm] Length of unit including connecting spigot</p> <p>L₁ [mm] Length of casing or acoustic cladding</p> <p>n [] Number of flange screw holes</p> <p>D [mm] Flange thickness</p> <p>m [kg] Unit weight including the minimum required attachments for manual adjustment</p> <p>f_m [Hz] Octave band centre frequency</p> <p>L_{PA} [dB(A)] A-weighted sound pressure level of air-regenerated noise of the VAV terminal unit, system attenuation taken into account</p> <p>L_{PA1} [dB(A)] A-weighted sound pressure level of air-regenerated noise of the VAV terminal unit with secondary silencer, system attenuation taken into account</p> <p>L_{PA2} [dB(A)] A-weighted sound pressure level of case-regenerated noise of the VAV terminal unit, system attenuation taken into account</p>	<p>L_{PA3} [dB(A)] A-weighted sound pressure level of case-regenerated noise of the VAV terminal unit with acoustic cladding, system attenuation taken into account</p> <p>Note on acoustic data: All sound pressure levels are based on a reference value of 20 µPa.</p> <p>q_{vnom} [m³/h]; [l/s] Nominal volume flow rate (100 %): The value depends on product type and nominal size. Values are published on the internet and in technical leaflets, and stored in the Easy Product Finder design software. Reference value for calculating percentages (e.g. qvmax). Upper limit of the setting range and maximum volume flow rate setpoint value for the VAV terminal unit.</p> <p>q_{vmin Unit} [m³/h]; [l/s] Technically possible minimum volume flow rate: The value depends on product type, nominal size and control component (attachment). Values are stored in the Easy Product Finder design software. Lower limit of the setting range and minimum volume flow rate setpoint value for the VAV terminal unit. Depending on the controller, setpoint values below qvmin unit (if qvmin equals zero) may result in unstable control or shut-off.</p> <p>q_{vmax} [m³/h]; [l/s] Upper limit of the operating range for the VAV terminal unit that can be set by customers: qvmax can only be smaller than or equal to qvnom. In case of analogue signalling to volume flow controllers (which are typically used), the set maximum value (qvmax) is allocated to the setpoint signal maximum (10 V) (see characteristic).</p> <p>q_{vmin} [m³/h]; [l/s] Lower limit of the operating range for the VAV terminal unit that can be set by customers: qvmin should be smaller than or equal to qvmax. Do not set qvmin smaller than qvmin unit, otherwise the control may become unstable or the damper blade may close. qvmin may equal zero. In case of analogue signalling to volume flow controllers (which are typically used), the set minimum value (qvmin) is allocated to the setpoint signal minimum (0 or 2 V) (see characteristic).</p> <p>q_v [m³/h]; [l/s] Volume flow rate</p> <p>Δ_{qv} [± %] Volume flow rate tolerance from setpoint value</p> <p>Δ_{pst} [Pa] Static differential pressure</p>
--	--

$\Delta_{\text{pst min}}$
[Pa]

Static differential pressure, minimum: The static minimum differential pressure is equal to the pressure loss of the VAV controller when the damper blade is open, caused by flow resistance (damper blade). If the pressure on the VAV controller is too low, the setpoint volume flow rate may not be achieved,

not even when the damper blade is open. Important factor in designing the ductwork and in rating the fan including speed control. Sufficient differential pressure must be ensured for all operating conditions and for all controllers, and the measurement point or points for speed control must have been selected accordingly to achieve this.