

Technical parameters

Nominal data	
Voltage (nominal)	400 V
Frequency	50 Hz
Phases	3~
Input power	1,379 W
Input current	3.16 A
Impeller speed	1,420 rpm
Air flow	max 8,446 m ³ /h
Temperature of transported air	max 70 °C
Max temperature of transported air, when speed controlled	70 °C
Sound data	
Sound pressure level at 3m (20m ² Sabin)	67 dB(A)
Protection/Classification	
Enclosure class, motor	IP54
Insulation class	F
Data according to ErP	
ErP ready	ErP 2018
Dimensions and weights	
Duct dimension, inlet (height x width)	500 x 800 mm
Duct dimension, outlet (height x width)	500 x 800 mm
Weight	67.4 kg
Others	
Duct connection type	Rectangular
Motor type	AC

Dimension

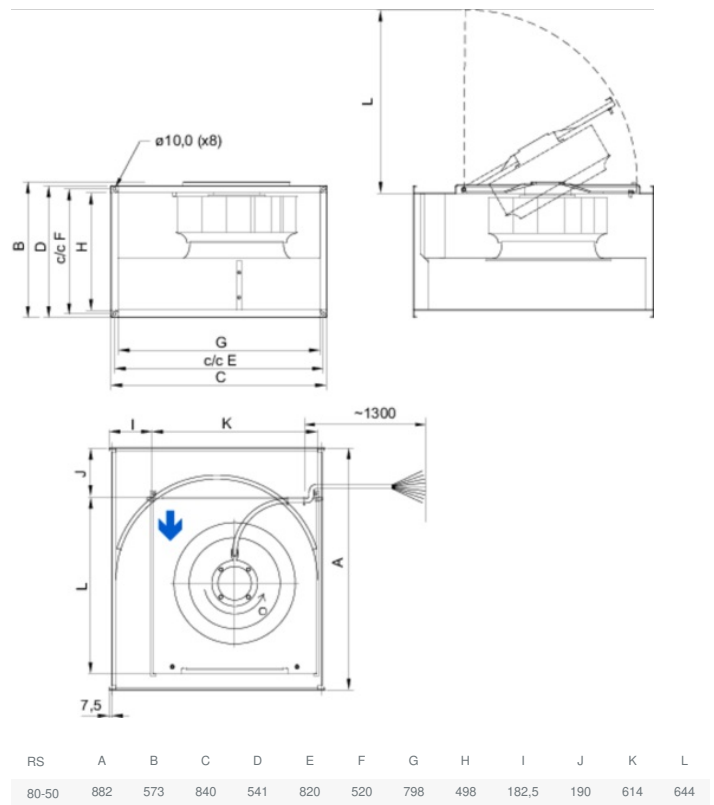

400V 3~

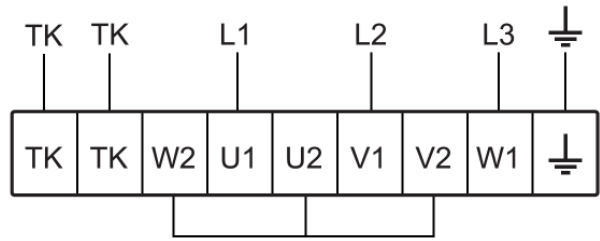

230V 3~



Performance curve

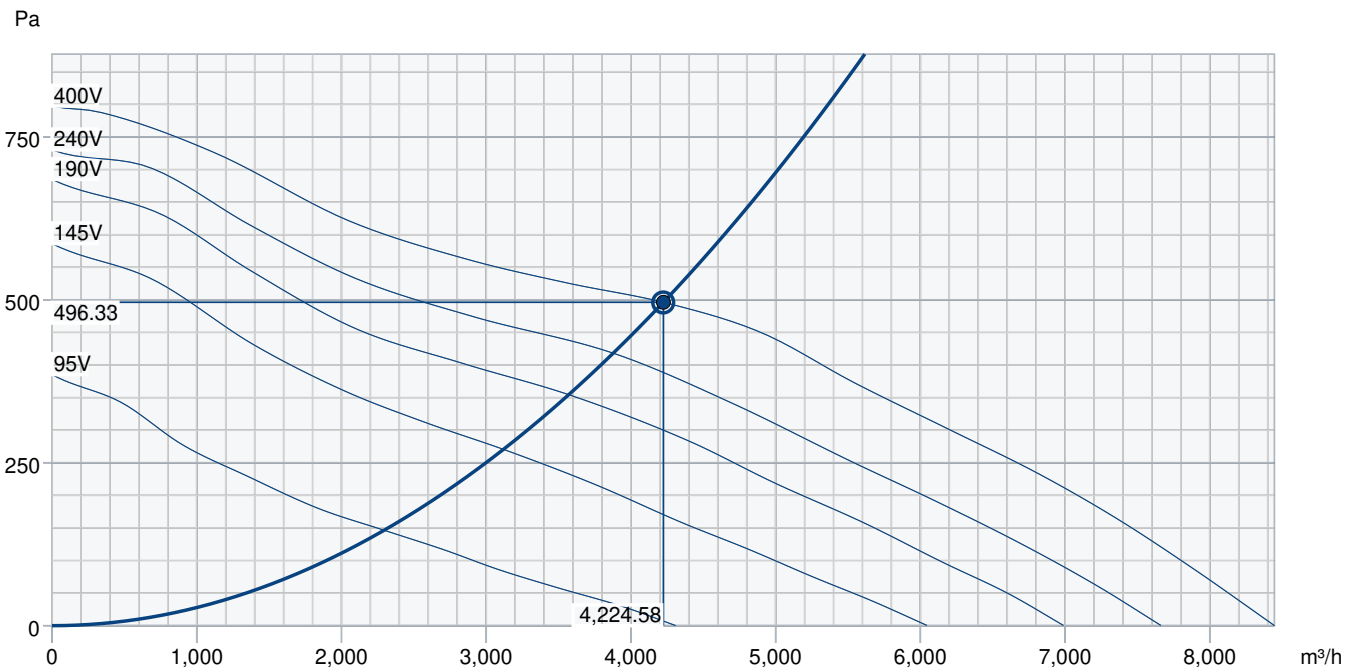

Hydraulic data										
Required air flow										4,223 m³/h
Required static pressure										496 Pa
Working air flow										4,225 m³/h
Working static pressure										496 Pa
Air density										1.204 kg/m³
Power										1,194.8 W
Fan control - RPM										1,431 rpm
Current										3.00 A
SFP										1.018 kW/m³/s
Control voltage										400.0 V
Supply voltage										400 V
Sound power level		63	125	250	500	1k	2k	4k	8k	Total
Inlet	dB(A)	65	75	74	75	74	74	69	62	82
Outlet	dB(A)	69	78	79	80	82	78	73	64	87
Surrounding	dB(A)	47	70	67	65	64	63	57	46	74
Sound pressure level at 3m (20m² Sabine)	dB(A)	-	-	-	-	-	-	-	-	67
Sound pressure level at 3m free field	dB(A)	-	-	-	-	-	-	-	-	53
Accessories										

Accessories

GFL 80-50 Counter flange (2711)

Motor protect. switch S-DT 16E (161207)

RTRD 7 speed control Systemair (5943)

CO2RT-R-D Transmitter (6993)

HR1 Room Humidistat (215150)

RT 0-30 Room Thermostat (5151)

T 120 Timer (5165)

DXRE 80-50-3-2,5 Duct cooler (7958)

LDR 80-50 Silencer (5075)

RB 80-50/45-3 400V/3 Duct heat (9647)

VBR 80-50-2 Water heating batt (5469)

Room hygrostat HR-S (286251)

TUNE-S-800x500-M4 (421369)

Motor protect. switch S-DT 16 (161206)

REV-5POL/07-7,5kW R/Y (33980)

RTRDU 7 Speed contr. Systemair (5947)

DTV500A (96807)

Presence detector/IR24-P (6995)

Safety switch 3-pole grey (210680)

DS 80-50 Flexible connection (1553)

FFK 80-50 filter cassette (30236)

PGK 80-50-3-2,0 Duct cooler (6619)

RB 80-50/68-4 400V/3 Duct heat (9648)

VBR 80-50-3 Water heating batt (5477)

TUNE-S-800x500-M0 (421365)

TUNE-S-800x500-M5 (421370)

Documents

INSTALLATION_OPERATION_AND_MAINTENANCE_INSTRUCTION_KE__KT__RS__RSI__EN_002.PDF

COMMISSIONING_RECORD_FANS__EN.PDF