

## PRF-EX Centrifugal Fans

### Speed controllable, explosion-proof efficiency

- Certified according to ATEX 2014/34/EU
- Handles Aggressive Media
- Flexible Use

[Find more details in our online catalogue](#)



### Safety first

PRF-EX fans are designed for challenging environments where explosive atmospheres can occur. Which is why they are tested according to ATEX directive 2014/34/EU – to ensure they'll perform as intended after installation.

### Flexibility

Where dirt, corrosive gases or other problematic elements occur, fans are exposed to particular challenges. Our **PRF-EX range** were specially developed for such applications in the food, electronics, medical facilities and chemical industries. With the help of robust and carefully selected components, there function reliably in unfavourably conditions.

### Modularity

The position of the unit's antistatic casing, which is made from UV-resistant and waterproof PP or PE, can be easily adapted. This making the PRF suitable for various configurations.

### Performance

**PRF-EX** could be used for temperature classes T1 to T4. Exhaust of potentially explosive gases in Zone 1 and Zone 2, as well as Groups IIA, IIB and hydrogen is also possible.

## Features

### Construction

Sintered casing made of UV-resistant PP or PE, waterproof. The casing can be easily adjusted through turning it (Standard position is LG270). The pedestal is manufactured of stainless steel, abrasion-resistant lacquered.

### Impeller

The PRF-EX fans use single-flow impellers made out of PP or GFK (PRF-EX 500D4 Ex d) with effective blade geometry, dynamically **balanced** and paired with corresponding **IEC Ex db motor**.

### Motor

Explosion proof motor Ex db with terminal box Ex eb on the motor.

### Motor protection

Integrated **PTC thermistors**, to be connected to a motor protection device.

### Control

Speed controllable by **frequency converter**.

### Installation

PRF-EX fans can be stand **on floor** with mounted **pedestal**. For **preventing vibration** to the duct is recommended to use **flexible connection**.

## Technical parameters

### Nominal data

Voltage (nominal)	400	V
Frequency	50	Hz
Motor circuit connection	Y	
Input power	1,377	W
Input power kW	1.377	kW
Starting current	13	A
Input current	2.3	A
Impeller speed	2,808	rpm
Air flow	max 2,070	m³/h
Temperature of transported air	max 60	°C
Max temperature of transported air, when speed controlled	60	°C

### Sound data

Sound pressure level at 3m (20m² Sabin)	69	dB(A)
---	----	-------

### Protection/Classification

Enclosure class, motor	IP55
Insulation class	F
Explosion proof marking	II 2G Ex h IIB+H2 T4 Gb
Certificate	TPS 19 ATEX 085751 0005 X

### Ambient and duct temperature

Ambient and duct temperature	-20 to 60	°C
------------------------------	-----------	----

### Dimensions and weights

Duct dimension; Circular, inlet	180	mm
Duct dimension; Circular, outlet	180	mm
Weight	37	kg

### Others

Duct connection type	Circular
Motor type	AC

Performance

Performance curve

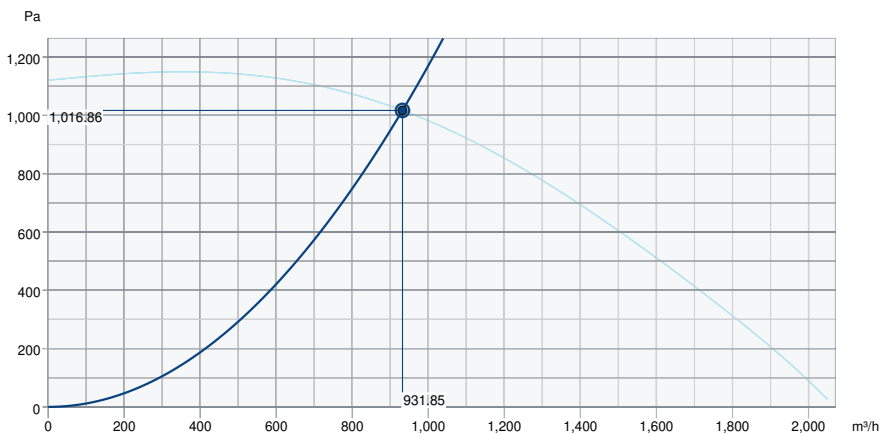

Hydraulic data

Required air flow	932 m³/h
Required static pressure	1,017 Pa
Working air flow	932 m³/h
Working static pressure	1,017 Pa
Air density	1.204 kg/m³
Power	776.5 W
Fan control - RPM	2,911 rpm
Current	1.49 A
SFP	3.000 kW/m³/s
Control voltage	400.0 V
Supply voltage	400 V

Sound power level		63	125	250	500	1k	2k	4k	8k	Total
Inlet	dB(A)	75	80	81	81	79	74	71	66	87
Outlet	dB(A)	81	80	84	86	83	77	69	61	90
Surrounding	dB(A)	58	51	61	73	70	66	62	54	76
Sound pressure level at 3m (20m² Sabine)	dB(A)	-	-	-	-	-	-	-	-	69
Sound pressure level at 3m free field	dB(A)	-	-	-	-	-	-	-	-	55

Dimension

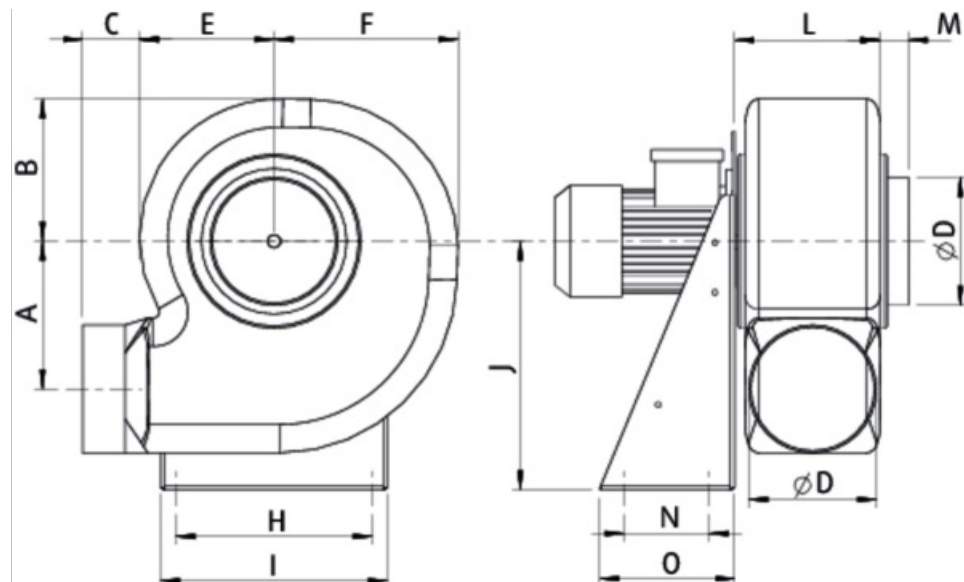

Typ	A	B	C	$\varnothing D$	E	F	H	I	J	L	M	N
PRF 180 EX	205	230	80	180	205	275	277	320	350	160	40	120

## Wiring

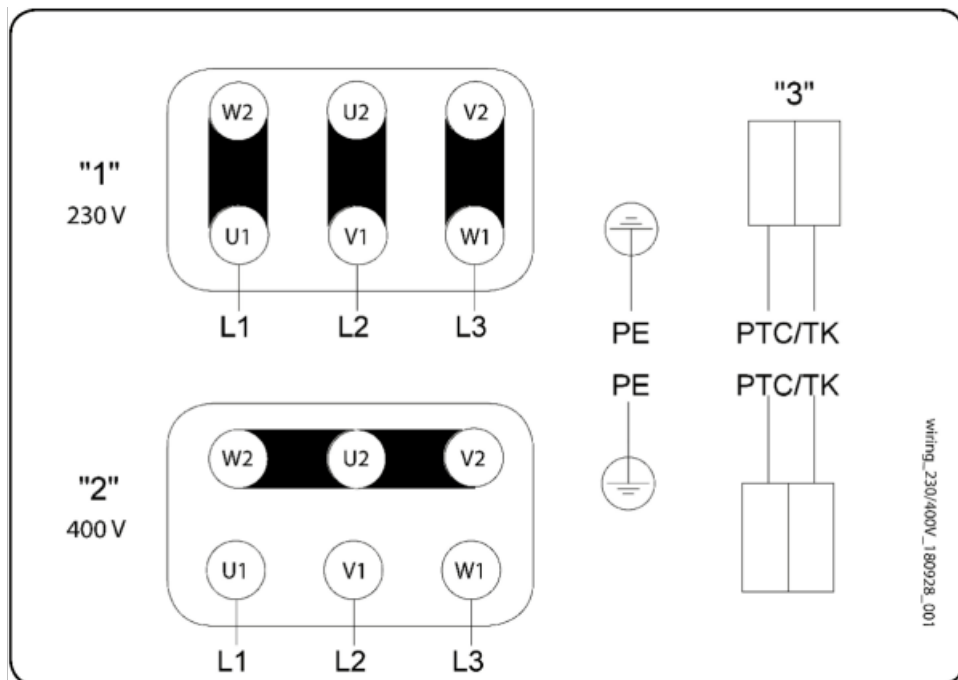

230/400V motor

"1" 3 x 230V Delta connection

"2" 3 x 400V Star connection

"3" Thermal motor protection optional

See motor name plate!

## Accessories

- ASS-P 180 flex. con. PRF (32379)
- Frequency converter FRQ5-4A (36229)
- Frequency converter FRQS-4A (36231)
- SD rubber mou. 4Pcs PRF160-250 (32568)
- VKA-P 180 adjust. damper PRF (32380)
- VP-Splinter protection PRF 180 (305463)
- REV-3POL/ATEX-11kW R/Y (36414)
- Frequency converter FRQ-4A (36227)
- Frequency converter FRQ5S-4A (36233)
- Frequency converter FXDM5AM (31387)
- U-EK230E Motor protection (30199)
- VKS-P 180 gravity shutter PRF (32381)
- FC102-1,5kW/4,1A-IP55, 150/50m (36159)

## Documents

- Installation and Operating Instructions\_012.pdf
- TPS 19 ATEX 085751 0005 X 01 EN.PDF
- TUV\_IT\_13\_ATEX\_039\_X\_REV\_2.PDF
- compatibility with chemical agents\_en\_003
- EU\_DECLARATION\_OF\_CONFORMITY\_ALL\_009\_314830.PDF
- CASING POSITION PRF.PDF