

Communicative damper actuator for adjusting dampers in technical building installations

- Air damper size up to approx. 2 m<sup>2</sup>
- Torque motor 10 Nm
- Nominal voltage AC/DC 24 V
- Control modulating, communicative 2...10 V variable
- Position feedback 2...10 V variable
- Conversion of sensor signals
- Communication via Belimo MP-Bus



Technical data

|                                   |   |  |
|-----------------------------------|---|--|
| <b>Electrical data</b>            | Nominal voltage   | AC/DC 24 V   |
|                                   | Nominal voltage frequency   | 50/60 Hz   |
|                                   | Nominal voltage range   | AC 19.2...28.8 V / DC 21.6...28.8 V                                  |
|                                   | Power consumption in operation  | 3.5 W  |
|                                   | Power consumption in rest position  | 1.4 W  |
|                                   | Power consumption for wire sizing   | 6 VA   |
|                                   | Connection supply / control   | Cable 1 m, 4 x 0.75 mm <sup>2</sup>                                  |
|                                   | Parallel operation  | Yes (note the performance data)                                      |
| <b>Functional data</b>            | Torque motor  | 10 Nm  |
|                                   | Torque variable   | 25%, 50%, 75% reduced  |
|                                   | Communicative control   | MP-Bus   |
|                                   | Operating range Y   | 2...10 V   |
|                                   | Input Impedance   | 100 kΩ   |
|                                   | Operating range Y variable  | Start point 0.5...30 V<br>End point 2.5...32 V                       |
|                                   | Options positioning signal  | Open/close<br>3-point (AC only)<br>Modulating (DC 0...32 V)          |
|                                   | Position feedback U   | 2...10 V   |
|                                   | Position feedback U note  | Max. 0.5 mA  |
|                                   | Position feedback U variable  | Start point 0.5...8 V<br>End point 2.5...10 V                        |
|                                   | Position accuracy   | ±5%  |
|                                   | Direction of motion motor   | selectable with switch 0/1   |
|                                   | Direction of motion note  | Y = 0 V: At switch position 0 (ccw rotation) /<br>1 (cw rotation)    |
|                                   | Direction of motion variable  | electronically reversible  |
|                                   | Manual override   | with push-button, can be locked                                      |
|                                   | Angle of rotation   | Max. 95°   |
|                                   | Angle of rotation note  | can be limited on both sides with adjustable<br>mechanical end stops |
|                                   | Running time motor  | 150 s / 90°  |
|                                   | Running time motor variable   | 43...173 s   |
|                                   | Adaptation setting range  | manual   |
| Adaptation setting range variable | No action<br>Adaptation when switched on<br>Adaptation after pushing the gear<br>disengagement button     |  |
| Override control                  | MAX (maximum position) = 100%<br>MIN (minimum position) = 0%<br>ZS (intermediate position, AC only) = 50% |  |

|                        |  |   |
|------------------------|--|---|
| <b>Functional data</b> | Override control variable              | MAX = (MIN + 32%)...100%<br>MIN = 0%...(MAX - 32%)<br>ZS = MIN...MAX  |
|                        | Sound power level, motor               | 35 dB(A)  |
|                        | Mechanical interface                   | Universal shaft clamp 8...26.7 mm   |
|                        | Position indication                    | Mechanically, pluggable   |
| <b>Safety data</b>     | Protection class IEC/EN                | III, Safety Extra-Low Voltage (SELV)  |
|                        | Power source UL                        | Class 2 Supply  |
|                        | Degree of protection IEC/EN            | IP54  |
|                        | Degree of protection NEMA/UL           | NEMA 2  |
|                        | Enclosure                              | UL Enclosure Type 2   |
|                        | EMC                                    | CE according to 2014/30/EU  |
|                        | Certification IEC/EN                   | IEC/EN 60730-1 and IEC/EN 60730-2-14  |
|                        | Certification UL                       | cULus according to UL60730-1A, UL60730-2-14 and CAN/CSA E60730-1<br>The UL marking on the actuator depends on the production site, the device is UL-compliant in any case |
|                        | Mode of operation                      | Type 1  |
|                        | Rated impulse voltage supply / control | 0.8 kV  |
|                        | Pollution degree                       | 3   |
|                        | Ambient temperature                    | -30...50°C  |
|                        | Storage temperature                    | -40...80°C  |
|                        | Ambient humidity                       | Max. 95% RH, non-condensing   |
|                        | Servicing                              | maintenance-free  |
| <b>Weight</b>          | Weight                                 | 0.77 kg   |

### Safety notes



- The device must not be used outside the specified field of application, especially not in aircraft or in any other airborne means of transport.
- Outdoor application: only possible in case that no (sea) water, snow, ice, insolation or aggressive gases interfere directly with the device and that it is ensured that the ambient conditions remain within the thresholds according to the data sheet at any time.
- Only authorised specialists may carry out installation. All applicable legal or institutional installation regulations must be complied during installation.
- The device may only be opened at the manufacturer's site. It does not contain any parts that can be replaced or repaired by the user.
- Cables must not be removed from the device.
- To calculate the torque required, the specifications supplied by the damper manufacturers concerning the cross-section, the design, the installation situation and the ventilation conditions must be observed.
- The device contains electrical and electronic components and must not be disposed of as household refuse. All locally valid regulations and requirements must be observed.

### Product features

- Mode of operation** Conventional operation:
- The actuator is connected with a standard modulating signal of 0...10 V and drives to the position defined by the positioning signal. The measuring voltage U serves for the electrical display of the actuator position 0.5...100% and as slave control signal for other actuators.
- Operation on Bus:
- The actuator receives its digital positioning signal from the higher level controller via the MP-Bus and drives to the position defined. Connection U serves as communication interface and does not supply an analogue measuring voltage.

|                                     |  |
|-------------------------------------|--|
| <b>Converter for sensors</b>        | Connection option for a sensor (passive or active sensor or switching contact). The MP actuator serves as an analogue/digital converter for the transmission of the sensor signal via MP-Bus to the higher level system.   |
| <b>Parametrisable actuators</b>     | The factory settings cover the most common applications. Single parameters can be modified with the Belimo Service Tools MFT-P or ZTH EU.  |
| <b>Simple direct mounting</b>       | Simple direct mounting on the damper shaft with a universal shaft clamp, supplied with an anti-rotation device to prevent the actuator from rotating.  |
| <b>Manual override</b>              | Manual override with push-button possible (the gear is disengaged for as long as the button is pressed or remains locked).   |
| <b>Adjustable angle of rotation</b> | Adjustable angle of rotation with mechanical end stops.  |
| <b>High functional reliability</b>  | The actuator is overload protected, requires no limit switches and automatically stops when the end stop is reached.   |
| <b>Home position</b>                | The first time the supply voltage is switched on, i.e. at the time of commissioning, the actuator carries out a synchronisation. The synchronisation is in the home position (0%).<br>The actuator then moves into the position defined by the positioning signal. |

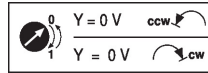

|                                       |  |
|---------------------------------------|--|
| <b>Adaptation and synchronisation</b> | <p>An adaption can be triggered manually by pressing the "Adaption" button or with the PC-Tool. Both mechanical end stops are detected during the adaption (entire setting range).</p> <p>Automatic synchronisation after pressing the gearbox disengagement button is configured. The synchronisation is in the home position (0%).</p> <p>The actuator then moves into the position defined by the positioning signal.</p> <p>A range of settings can be adapted using the PC-Tool (see MFT-P documentation)</p> |
|---------------------------------------|--|

**Accessories**

| Gateways               | Description   | Type       |
|------------------------|---|------------|
|                        | Gateway MP zu BACnet MS/TP                                | UK24BAC    |
|                        | Gateway MP to Modbus RTU                                  | UK24MOD    |
| Electrical accessories | Description   | Type       |
|                        | Positioner for wall mounting                              | CRP24-B1   |
|                        | Feedback potentiometer 10 kΩ add-on                       | P10000A    |
|                        | Feedback potentiometer 1 kΩ add-on                        | P1000A     |
|                        | Feedback potentiometer 140 Ω add-on                       | P140A      |
|                        | Feedback potentiometer 200 Ω add-on                       | P200A      |
|                        | Feedback potentiometer 2.8 kΩ add-on                      | P2800A     |
|                        | Feedback potentiometer 5 kΩ add-on                        | P5000A     |
|                        | Feedback potentiometer 500 Ω add-on                       | P500A      |
|                        | Auxiliary switch 1 x SPDT add-on                          | S1A        |
|                        | Auxiliary switch 2 x SPDT add-on                          | S2A        |
|                        | Positioner for wall mounting                              | SGA24      |
|                        | Positioner for built-in mounting                          | SGE24      |
|                        | Positioner for front-panel mounting                       | SGF24      |
|                        | Signal converter voltage/current 100 kΩ Supply AC/DC 24 V | Z-UIC      |
|                        | MP-Bus power supply for MP actuators                      | ZN230-24MP |

| Mechanical accessories | Description   | Type        |
|------------------------|---|-------------|
|                        | Angle of rotation limiter for K-NA and K-SA   | 20334-00001 |
|                        | Actuator arm for standard shaft clamp (one-sided)   | AH-25       |
|                        | Shaft extension 240 mm Ø20 mm for damper shaft Ø 8...22.7 mm  | AV8-25      |
|                        | Shaft clamp one-sided, clamping range Ø8...26 mm with insert, Multipack 20 pcs.   | K-ENMA      |
|                        | Shaft clamp one-sided, clamping range Ø8...26 mm, Multipack 20 pcs.   | K-ENSA      |
|                        | Shaft clamp reversible, clamping range Ø8...20 mm   | K-NA        |
|                        | Ball joint suitable for damper crank arm KH8 / KH10   | KG10A       |
|                        | Ball joint suitable for damper crank arm KH8  | KG8         |
|                        | Damper crank arm Slot width 8.2 mm, clamping range Ø10...18 mm  | KH8         |
|                        | Anti-rotation mechanism 180 mm, Multipack 20 pcs.   | Z-ARS180    |
|                        | Base plate extension for NM..A to NM.., pcs.  | Z-NMA       |
|                        | Position indicator, Multipack 20 pcs.   | Z-PI        |
|                        | Form fit insert 10x10 mm, Multipack 20 pcs.   | ZF10-NSA    |
|                        | Form fit insert 12x12 mm, Multipack 20 pcs.   | ZF12-NSA    |
|                        | Form fit insert 15x15 mm, Multipack 20 pcs.   | ZF15-NSA    |
|                        | Form fit insert 16x16 mm, Multipack 20 pcs.   | ZF16-NSA    |
|                        | Form fit insert 8x8 mm, Multipack 20 pcs.   | ZF8-NMA     |
|                        | Mounting kit for linkage operation for flat installation  | ZG-NMA      |
| Service tools          | Description   | Type        |
|                        | Adapter for Service-Tool ZTH  | MFT-C       |
|                        | Belimo PC-Tool, Software for adjustments and diagnostics  | MFT-P       |
|                        | Connection cable 5 m, A: RJ11 6/4 ZTH EU, B: 6-pin for connection to service socket   | ZK1-GEN     |
|                        | Connection cable 5 m, A: RJ11 6/4 ZTH EU, B: free wire end for connection to MP/PP terminal   | ZK2-GEN     |
|                        | Service Tool, with ZIP-USB function, for parametrisable and communicative Belimo actuators, VAV controller and HVAC performance devices | ZTH EU      |

**Electrical installation**

**Supply from isolating transformer.**
**Parallel connection of other actuators possible. Observe the performance data.**
**Wiring diagrams**

AC/DC 24 V, modulating

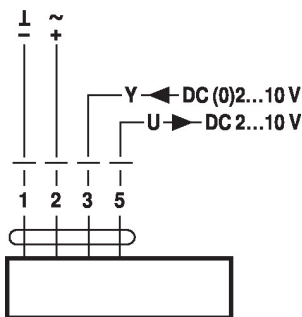
**Cable colours:**

- 1 = black
- 2 = red
- 3 = white
- 5 = orange

Operation on the MP-Bus

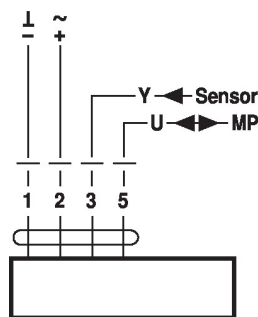

**Cable colours:**

- 1 = black
- 2 = red
- 3 = white
- 5 = orange

**Functions**

**Functions when operated on MP-Bus**

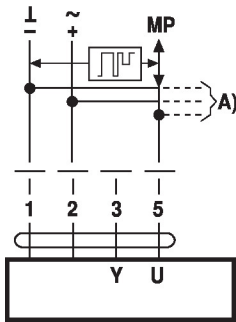
Connection on the MP-Bus



A) additional MP-Bus nodes (max. 8)

MP-Bus Network topology

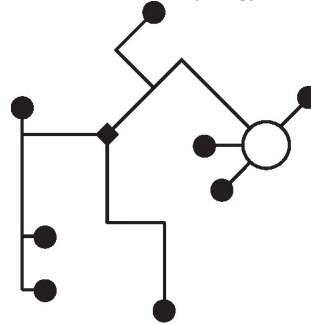

There are no restrictions for the network topology (star, ring, tree or mixed forms are permitted). Supply and communication in one and the same 3-wire cable

- no shielding or twisting necessary
- no terminating resistors required

Connection of active sensors

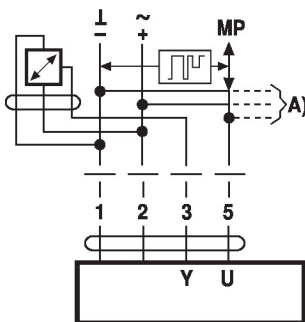

A) additional MP-Bus nodes (max. 8)

- Supply AC/DC 24 V
- Output signal DC 0...10 V (max. DC 0...32 V)
- Resolution 30 mV

Connection of external switching contact

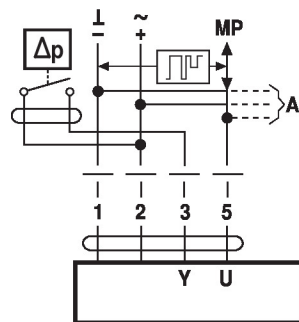

A) additional MP-Bus nodes (max. 8)

- Switching current 16 mA @ 24 V
- Start point of the operating range must be parametrised on the MP actuator as  $\geq 0.5$  V

Connection of passive sensors

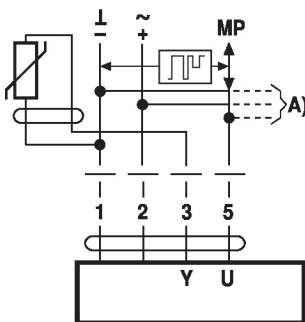

|               |                            |                             |
|---------------|----------------------------|-----------------------------|
| <b>Ni1000</b> | -28...+98°C                | 850...1600 Ω <sup>2)</sup>  |
| <b>PT1000</b> | -35...+155°C               | 850...1600 Ω <sup>2)</sup>  |
| <b>NTC</b>    | -10...+160°C <sup>1)</sup> | 200 Ω...60 kΩ <sup>2)</sup> |

A) additional MP-Bus nodes (max. 8)

1) Depending on the type  
2) Resolution 1 Ohm  
Compensation of the measured value is recommended

**Functions with basic values (conventional mode)**

Override control with AC 24 V with relay contacts

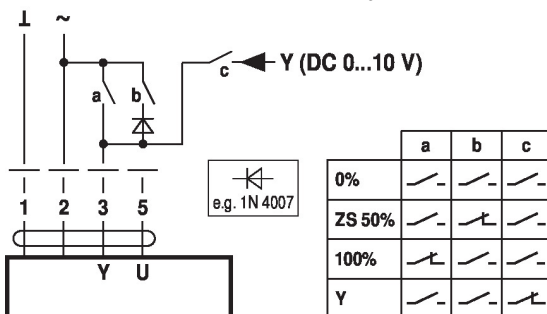

Override control with AC 24 V with rotary switch

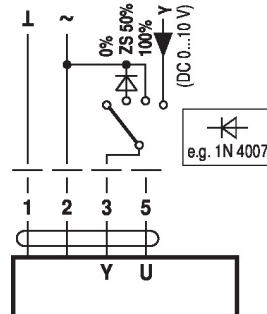

Control remotely 0...100% with positioner SG..

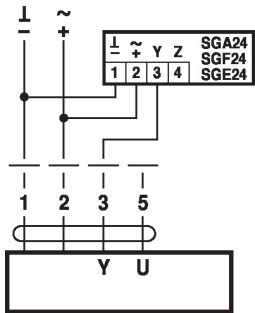

Minimum limit with positioner SG..

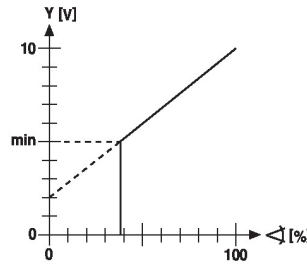
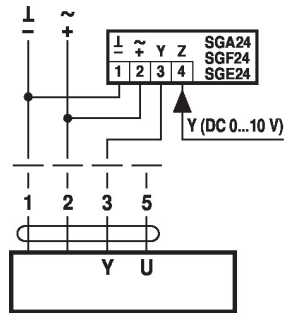

Follow-up control (position-dependent)

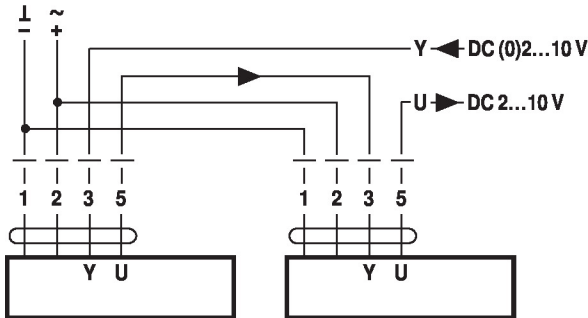

Control with 4...20 mA via external resistor

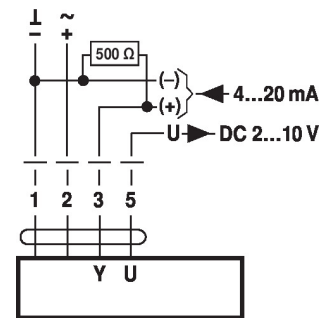

**Caution:**  
The operating range must be set to DC 2...10 V.  
The 500 Ω resistor converts the 4...20 mA current signal to a voltage signal DC 2...10 V

Functional check

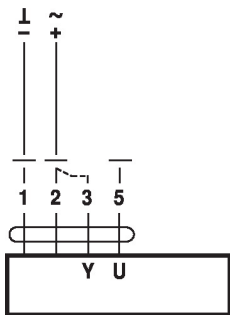

**Procedure**

1. Connect 24 V to connections 1 and 2
2. Disconnect connection 3:
  - with direction of rotation 0: Actuator rotates to the left
  - with direction of rotation 1: Actuator rotates to the right
3. Short-circuit connections 2 and 3:
  - Actuator runs in opposite direction

**Functions for actuators with specific parameters (Parametrisation necessary)**

Override control and limiting with AC 24 V with relay contacts

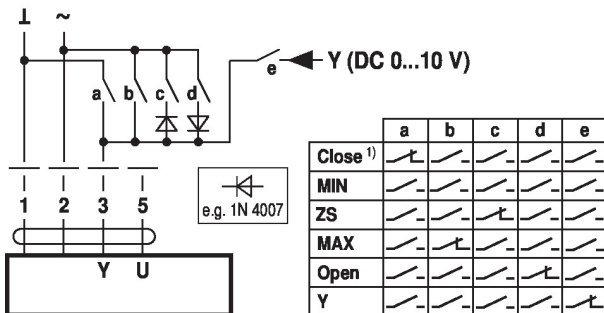

Override control and limiting with AC 24 V with rotary switch

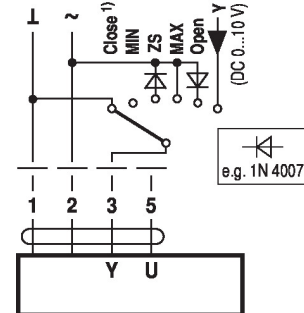

1) **Caution:** This function is only guaranteed if the start point of the operating range is defined as min. 0.5 V.

Control open/close

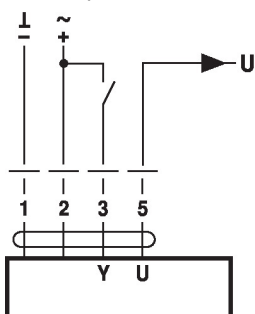

Control 3-point

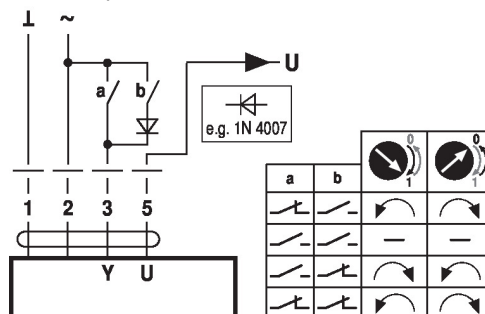

Operating controls and indicators

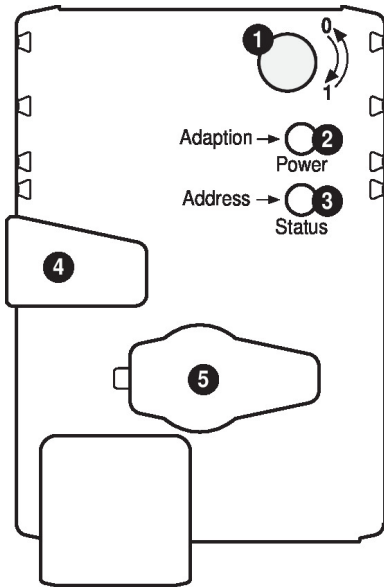

- 1 Direction of rotation switch**  
Switch over: Direction of rotation changes
- 2 Push-button and LED display green**  
Off: No power supply or malfunction  
On: In operation  
Press button: Triggers angle of rotation adaptation, followed by standard mode
- 3 Push-button and LED display yellow**  
Off: Standard mode  
Flickering: MP communication active  
On: Adaptation or synchronising process active  
Flashing: Request for addressing from MP master  
Press button: Confirmation of the addressing
- 4 Gear disengagement button**  
Press button: Gear disengages, motor stops, manual override possible  
Release button: Gear engages, synchronisation starts, followed by standard mode
- 5 Service plug**  
For connecting parameterisation and service tools

**Check power supply connection**

- 2 Off and 3 On** Possible wiring error in power supply

Service

**Service Tools connection** The actuator can be parametrised by ZTH EU via the service socket. For an extended parametrisation the PC tool can be connected.

Connection ZTH EU / PC-Tool

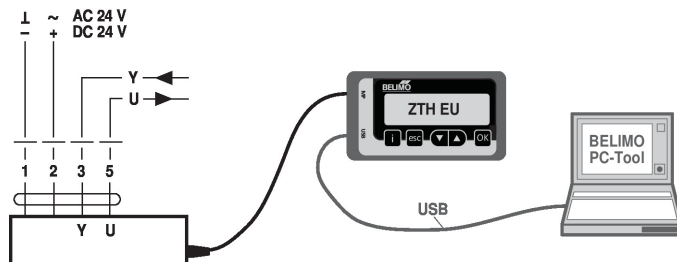

Dimensions

Dimensional drawings

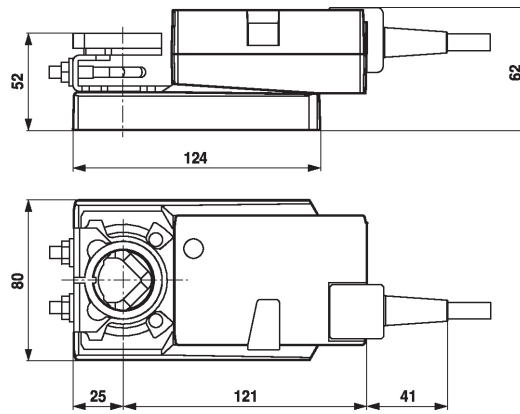

Clamping range

|  | 8...26.7 | ≥8 | ≤26.7 |
|--|----------|----|-------|
|  | 8...20   | ≥8 | ≤20   |

\* Option (Accessory K-NA)

\*Option: Shaft clamp mounted below (accessories K-NA needed)

Shaft length

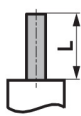

Min. 40

Min. 20

Further documentation

- Overview MP Cooperation Partners
- Tool connections
- Introduction to MP-Bus Technology

Application notes

- For digital control of actuators in VAV applications patent EP 3163399 must be considered.