

- Torque motor 5 Nm
- Nominal voltage AC/DC 24 V
- Control communicative
- Conversion of sensor signals
- Communication via KNX (S-Mode)



Technical data

Electrical data	Nominal voltage	AC/DC 24 V
	Nominal voltage frequency	50/60 Hz
	Nominal voltage range	AC 19.2...28.8 V / DC 21.6...28.8 V
	Power consumption in operation	2.5 W
	Power consumption in rest position	1.3 W
	Power consumption for wire sizing	5 VA
	Connection supply / control	Cable 1 m, 6 x 0.75 mm ²
Data bus communication	Medium	KNX TP
	Number of nodes	max. 64 per line segment, reduce number of nodes with connection cable with short lines
	Operating mode	S-Mode
	Current consumption of KNX-Bus	max. 5 mA
Functional data	Torque motor	5 Nm
	Torque variable	25%, 50%, 75% reduced
	Communicative control	KNX (S-Mode)
	Direction of motion motor	selectable with switch 0/1
	Direction of motion note	Y = 0%: At switch position 0 (ccw rotation) / 1 (cw rotation)
	Direction of motion variable	electronically reversible
	Manual override	with push-button, can be locked
	Running time motor	150 s / 90°
	Running time motor variable	35...150 s
	Adaptation setting range	manual
	Adaptation setting range variable	No action Adaptation when switched on Adaptation after pushing the gear disengagement button
	Override control	MAX (maximum position) = 100% MIN (minimum position) = 0%
	Override control, controllable via bus communication	MAX (maximum position) = 100% MIN (minimum position) = 0% ZS (intermediate position) = 50%
	Override control variable	MAX = (MIN + 32%)...100% MIN = 0%...(MAX - 32%) ZS = MIN...MAX
	Sound power level, motor	35 dB(A)
Position indication	Mechanically, pluggable	
Safety data	Protection class IEC/EN	III, Safety Extra-Low Voltage (SELV)
	Degree of protection IEC/EN	IP54
	EMC	CE according to 2014/30/EU

Safety data	Certification IEC/EN	IEC/EN 60730-1 and IEC/EN 60730-2-14
	Mode of operation	Type 1
	Rated impulse voltage supply / control	0.8 kV
	Pollution degree	3
	Ambient temperature	-30...50°C
	Storage temperature	-40...80°C
	Ambient humidity	Max. 95% RH, non-condensing
	Servicing	maintenance-free
Weight	Weight	0.55 kg

Safety notes

- The device must not be used outside the specified field of application, especially not in aircraft or in any other airborne means of transport.
- Outdoor application: only possible in case that no (sea) water, snow, ice, insolation or aggressive gases interfere directly with the device and that it is ensured that the ambient conditions remain within the thresholds according to the data sheet at any time.
- Only authorised specialists may carry out installation. All applicable legal or institutional installation regulations must be complied during installation.
- The device may only be opened at the manufacturer's site. It does not contain any parts that can be replaced or repaired by the user.
- Cables must not be removed from the device.
- To calculate the torque required, the specifications supplied by the damper manufacturers concerning the cross-section, the design, the installation situation and the ventilation conditions must be observed.
- The device contains electrical and electronic components and must not be disposed of as household refuse. All locally valid regulations and requirements must be observed.

Product features

Mode of operation	The actuator is equipped with an integrated interface for KNX (S-Mode) and can be connected with all KNX devices that have corresponding data points available.
Converter for sensors	Connection option for a sensor (passive or active sensor or switching contact). In this way, the analogue sensor signal can be easily digitised and passed along to KNX.
Parametrisable actuators	The factory settings cover the most common applications. As desired, individual parameters can be adapted for specific systems or servicing with a service tool (e.g. ZTH EU) or the ETS planning and commissioning tool.
Simple direct mounting	Simple direct mounting on the damper shaft with a universal shaft clamp, supplied with an anti-rotation device to prevent the actuator from rotating.
Manual override	Manual override with push-button possible (the gear is disengaged for as long as the button is pressed or remains locked).
Adjustable angle of rotation	Adjustable angle of rotation with mechanical end stops.
High functional reliability	The actuator is overload protected, requires no limit switches and automatically stops when the end stop is reached.
Home position	The first time the supply voltage is switched on, i.e. at the time of commissioning, the actuator carries out a synchronisation. The synchronisation is in the home position (0%). The actuator then moves into the position defined by the positioning signal.

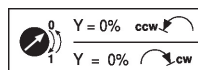

Adaptation and synchronisation

An adaption can be triggered manually by pressing the "Adaption" button or with the PC-Tool. Both mechanical end stops are detected during the adaption (entire setting range).

Automatic synchronisation after pressing the gearbox disengagement button is configured. The synchronisation is in the home position (0%).

The actuator then moves into the position defined by the positioning signal.

A range of settings can be adapted using the PC-Tool (see MFT-P documentation)

Accessories

Electrical accessories	Description	Type
	Feedback potentiometer 10 kΩ add-on	P10000A
	Feedback potentiometer 1 kΩ add-on	P1000A
	Feedback potentiometer 140 Ω add-on	P140A
	Feedback potentiometer 200 Ω add-on	P200A
	Feedback potentiometer 2.8 kΩ add-on	P2800A
	Feedback potentiometer 5 kΩ add-on	P5000A
	Feedback potentiometer 500 Ω add-on	P500A
	Auxiliary switch 1 x SPDT add-on	S1A
	Auxiliary switch 2 x SPDT add-on	S2A
Mechanical accessories	Description	Type
	Shaft extension 170 mm Ø10 mm for damper shaft Ø 6...16 mm	AV6-20
	Shaft clamp one-sided, clamping range Ø6...20 mm, Multipack 20 pcs.	K-ELA
	Shaft clamp one-sided, clamping range Ø6...10 mm, Multipack 20 pcs.	K-ELA10
	Shaft clamp one-sided, clamping range Ø6...13 mm, Multipack 20 pcs.	K-ELA13
	Shaft clamp one-sided, clamping range Ø6...16 mm, Multipack 20 pcs.	K-ELA16
	Anti-rotation mechanism 180 mm, Multipack 20 pcs.	Z-ARS180
	Position indicator, Multipack 20 pcs.	Z-PI
	Form fit insert 10x10 mm, Multipack 20 pcs.	ZF10-LMA
	Form fit insert 12x12 mm, Multipack 20 pcs.	ZF12-LMA
	Form fit insert 8x8 mm, Multipack 20 pcs.	ZF8-LMA
	Form fit insert 10x10 mm, with angle of rotation limiter and position indication, Multipack 20 pcs.	ZFRL10-LMA
	Form fit insert 12x12 mm, with angle of rotation limiter and position indication, Multipack 20 pcs.	ZFRL12-LMA
	Form fit insert 8x8 mm, with angle of rotation limiter and position indication, Multipack 20 pcs.	ZFRL8-LMA
Service tools	Description	Type
	Adapter for Service-Tool ZTH	MFT-C
	Belimo PC-Tool, Software for adjustments and diagnostics	MFT-P
	Connection cable 5 m, A: RJ11 6/4 ZTH EU, B: 6-pin for connection to service socket	ZK1-GEN
	Connection cable 5 m, A: RJ11 6/4 ZTH EU, B: free wire end for connection to MP/PP terminal	ZK2-GEN
	Service Tool, with ZIP-USB function, for parametrisable and communicative Belimo actuators, VAV controller and HVAC performance devices	ZTH EU

Electrical installation

Supply from isolating transformer.

Wiring diagrams

Connection without sensor

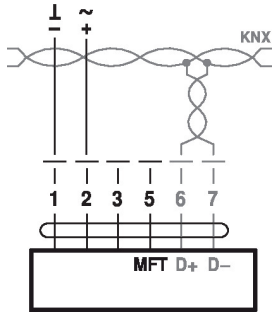

Signal assignment KNX:
 D+ = KNX+ (pink > red)
 D- = KNX- (grey > black)
 The connection to the KNX line should take place via WAGO connecting terminals 222/221.

Connection with passive sensor, e.g. Pt1000, Ni1000, NTC

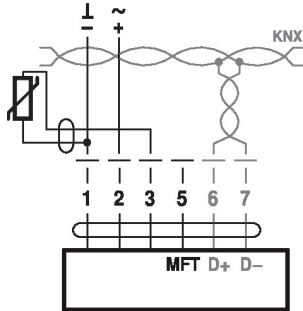

Ni1000	-28...+98°C	850...1600 Ω ²⁾
PT1000	-35...+155°C	850...1600 Ω ²⁾
NTC	-10...+160°C ¹⁾	200 Ω...60 kΩ ²⁾

1) depending on type
 2) Resolution 1 Ohm
 Compensation of the measured value is recommended

Connection with switching contact, e.g. pressure control device

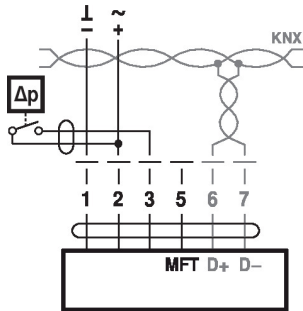

Requirements switching contact:
 The switching contact must be able to accurately switch a current of 16 mA@24 V.

KNX group objects

Name	Type	Flags					Data point type				Values range	
		C	R	W	T	U	ID	DPT_Name	Format	Unit		
Setpoint	I	C	-	W	-	-	5.001	_Scaling	1 Byte	%	[0...100] Resolution 0.4%	
Override control	I	C	-	W	-	-	20.*	_Enum	1 Byte	-	0 = no override 1 = Open 2 = Closed 3 = Min 4 = Mid 5 = Max	
Reset	I	C	-	W	-	-	1.015	_Reset	1 Bit	-	0 = no action 1 = reset	
Adaptation	I	C	-	W	-	-	1.017	_Switch	1 Bit	-	0 = no action 1 = adapt	
Testrun	I	C	-	W	-	-	1.017	_Switch	1 Bit	-	0 = no action 1 = Testrun	
Min	I/O	C	R	W	-	-	5.001	_Scaling	1 Byte	%	[0...100] Resolution 0.4%	
Max	I/O	C	R	W	-	-	5.001	_Scaling	1 Byte	%	[0...100] Resolution 0.4%	
Relative position	O	C	R	-	T	-	5.001	_Scaling	1 Byte	%	[0...100] Resolution 0.4%	
Absolute position	O	C	R	-	T	-	8.011 7.011	_Rotation_Angle _Length_mm	2 Byte	° mm	[-32,768...32,768] [0...65,535]	
Fault state	O	C	R	-	T	-	1.002	_Bool	1 Bit	-	0 = no fault 1 = fault	
Overridden	O	C	R	-	T	-	1.002	_Bool	1 Bit	-	0 = not active 1 = active	
Gear disengaged	O	C	R	-	T	-	1.002	_Bool	1 Bit	-	0 = engaged 1 = disengaged	
Service information	O	C	R	-	T	-	22.*	_Bitset16	2 Byte	-	Bit 0 (1)	Excessive utilisation
											Bit 1 (2)	Mechanical travel increased
											Bit 2 (4)	Mechanical overload
											Bit 3 (8)	– (Not used)
											Bit 4 (16)	– (Not used)
											Bit 5 (32)	– (Not used)
											Bit 6 (64)	– (Not used)
											Bit 7 (128)	– (Not used)
											Bit 8 (256)	Internal activity
											Bit 9 (512)	Bus watchdog triggered
Sensor value	O	C	R	-	T	-						
– Resistance R							14.060	_Value_Resistance	4 Byte	Ω	–	
– Temperature							9.001	_Value_Temp	2 Byte	°C	[-273.....670'760]	
– Relative humidity							9.007	_Value_Humidity	2 Byte	% rH	[0...670'760]	
– Air quality							9.008	_Value_AirQuality	2 Byte	ppm	[0...670'760]	
– Voltage mV							9.020	_Value_Voltage	2 Byte	mV	[-670'760...670'760]	
– Voltage scaled							7.*	–	2 Byte	–	[0...65'535]	
– Voltage scaled %							5.001	_Scaling	1 Byte	%	[0...100]	
– Switch							1.001	_Switch	–	–	0/1	

KNX group objects

Setpoint	Specification of actuator position in % between the parameterised Min and Max limits.
Override control	Overriding the setpoint with defined override states. As data point type, 1 Byte (unsigned) is recommended (DPT 20.*)
Reset	Resetting the stored service messages (see KNX group object <i>Service information</i>).
Adaptation	Perform the adaptation. An active adaptation is signaled in Bit 8 of <i>Service information</i> .
Testrun	Performance of a testrun that checks the entire operating range. An active testrun is signaled in Bit 8 of <i>Service information</i> . After completion, detected faults (mechanical overload, mechanical travel increased) are signaled in <i>Service Information</i> .
Min	Minimum Limit (position) in %. Caution: Changing the setting may result in malfunctions.
Max	Maximum Limit (position) in %. Caution: Changing the setting may result in malfunctions.
Relative position	Current actuator position in %
Absolute position	Absolute position/stroke The data point type is to be selected depending on the type of movement: [°] DPT 8.011 [mm] DPT 7.011
Fault state	Collective fault based on Bit 0 ... Bit 7 of <i>Service information</i>
Overridden	Signaling of an active override control (OPEN/CLOSED) The device can be commanded via the KNX group object <i>Override control</i> or via the forced switching at the input Y/3. Only the override controls OPEN and CLOSED are signaled.
Gear disengaged	Signaling an active gear disengagement
Service information	Detailed information regarding device status As data point type, Bitset 16-Bit is recommended (DPT 22.*) Status information Bit 0: Motor operation in relation to operating period too high Bit 1: Mechanical travel increased, e.g. defined end position exceeded Bit 2: Mechanical overload, i.e. defined end position not reached Bit 3 ... 7: not used with this device type Bit 8: Internal activity (Synchronisation, Adaptation, Testrun, ...) Bit 9: Bus watchdog triggered Bit 0 ... Bit 7 are stored by the device and can be reset with the KNX group object <i>Reset</i> . As an alternative, the several bits can be read as collective fault state.
Sensor value	The representation of the sensor value is dependent on the parameterization. See section "KNX parameters – Sensor"

KNX parameters

Common

Setpoint at bus failure A setpoint can be defined for cases of communication interruption.

Values range: None (last setpoint)
 Open
 Closed
 Mid

Factory setting: None (last setpoint)

The monitoring of the communication takes place for the KNX group objects *Setpoint* and *Override control*. If none of the objects is written within the parameterised monitoring time, the bus fail position is set and signaled in the *Service information* (Bit 9).

Bus timeout [min] Monitoring time for the detection of a communication interruption.

Values range: 1 ... 120 min
 Factory setting: –

Increment for value update [%] Actual values (position, volumetric flow) are transferred at the time of a value change insofar as these change by the parameterised difference value. If the relative value changes by the difference value, not only the relative actual value but also the absolute actual value are transferred.

Values range: 0 ... 100%
 Factory setting: 5%

The transfer is deactivated with 0% in the event of a value change.

Repetition time [s] Repetition time for all position and sensor actual values. Status objects are not transferred except with a change.

Values range: 0 ... 3600 s
 Factory setting: 0 = no periodic transmission

Sensor

Sensor type The input Y/3 can be used to connect a sensor. The sensor value is digitised and made available as KNX communication object.

Values range: No sensor
 Active sensor (0 ... 32 V)
 Passive sensor 1 K
 Passive sensor 20 K
 Switch (0 / 1)
 Temperature sensor PT1000 / Ni1000 / NTG10K
 Humidity sensor (0 ... 10 V corresponds to 0 ... 100%)
 Air quality sensor CO2 (0 ... 10 V corresponds to 0 ... 2000 ppm)

Factory setting: No sensor

A switching to Y/3 is treated as local override in the absence of sensor parameterization.

Increment for sensor value update The sensor value is transferred at the time of a value change insofar as this changes by the parameterised difference value.

Values range: 0 ... 65,535
 Factory setting: 1

The transfer is deactivated with 0 in the event of a value change. Without value change, the sensor value is sent because of the repetition time.

Output (for sensor type "Active sensor") Only for "Active sensor" sensor type

Values range: Sensor value mV (DPT 9.020)
 Sensor value scaled (DPT 7.xxx)
 Sensor value scaled % (DPT 5.001)

Factory setting: –

For "Sensor value mV", the measured voltage is made available without processing. In the case of the scaled sensor values, a linear transformation can be defined with two points.

Polarity (for sensor type "Switch") The polarity can be defined for the sensor type "Switch".

Values range: Normal
 Inverted

Factory setting: –

KNX workflows

- Product database** The product database for the import in ETS4 or higher is available at the Belimo website.
- Setting physical address** The programming of the physical address takes place by ETS and the programming button on the device.
- If the programming button is not accessible or accessible only with difficulty, then the address can be set using a point-to-point connection: "Overwrite Individual Address: 15.15.255"
- As a third possibility, the physical address can be programmed on the basis of the KNX series number (e.g. with Moov'n'Group). The KNX series number is placed on the device in two versions. One sticker can be removed for adhesion on the commissioning journal, for example.
- Firmware upgrade** The KNX firmware of the device is updated automatically with the programming of the application program if the product database has a more recent version.
- The first programming procedure takes somewhat longer in such cases (>1 min).
- Resetting to KNX factory settings** If necessary, the device can be reset manually to the KNX factory settings (physical address, group address, KNX parameters).
- For the reset, the programming button on the device must be pressed down for at least 5 s during start-up.

Operating controls and indicators

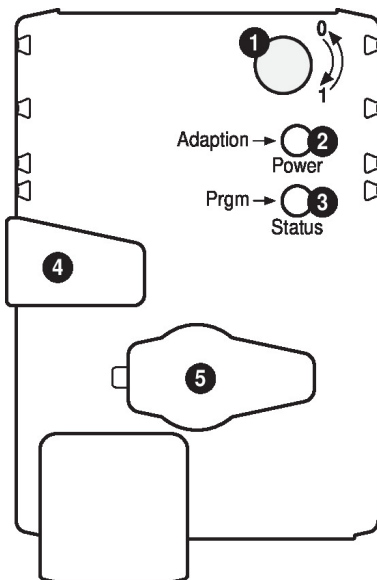

- 1 Direction of rotation switch**
Switch over: Direction of rotation changes
- 2 Push-button and LED display green**
Off: No power supply or malfunction
On: In operation
Press button: Triggers angle of rotation adaptation, followed by standard mode
- 3 Push-button and LED display yellow**
Off: The actuator is ready
On: Adaptation or synchronising process active or actuator in programming mode (KNX)
Flashing: Connection test (KNX) active
Press button: In operation (>3 s): Switch the programming mode on and off (KNX)
When starting (>5 s): Reset to factory setting (KNX)
- 4 Gear disengagement button**
Press button: Gear disengages, motor stops, manual override possible
Release button: Gear engages, synchronisation starts, followed by standard mode
- 5 Service plug**
For connecting parameterisation and service tools

Service

- Service Tools connection** The actuator can be parametrised by ZTH EU via the service socket. For an extended parameterisation the PC tool can be connected.

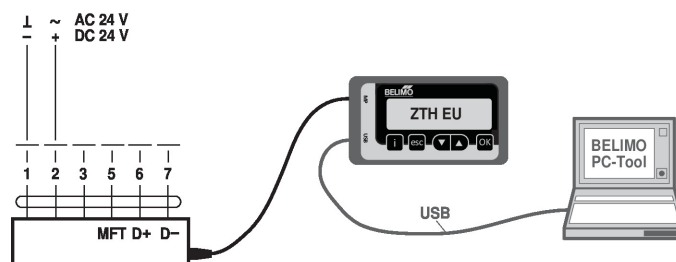

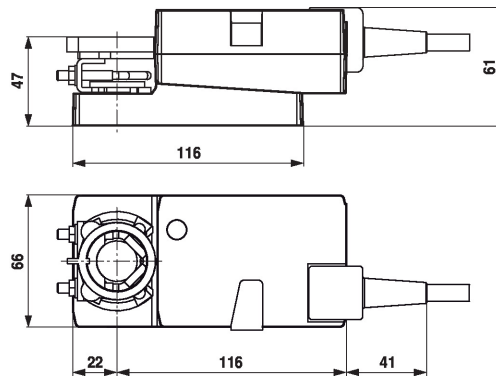
Dimensions**Dimensional drawings****Further documentation**

- Tool connections
- General notes for project planning

Application notes

- For digital control of actuators in VAV applications patent EP 3163399 must be considered.