

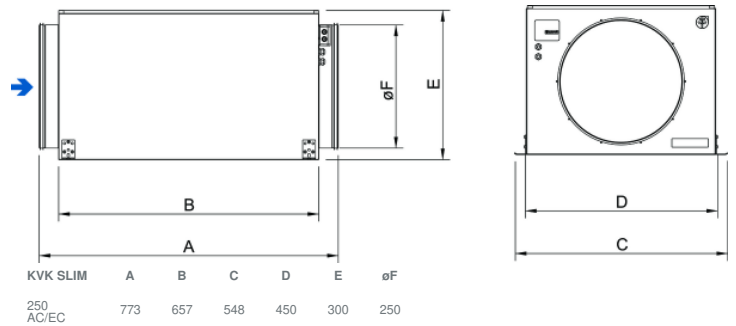

## Technical parameters

Nominal data	
Voltage (nominal)	230 V
Frequency	50 Hz
Phases	1~
Input power	241 W
Input current	1.05 A
Impeller speed	2,694 rpm
Air flow	max 1,318 m <sup>3</sup> /h
Capacitance of capacitor	6 μF
Temperature of transported air	max 70 °C
Max temperature of transported air, when speed controlled	70 °C
Sound data	
Sound pressure level at 3m (20m <sup>2</sup> Sabin)	55 dB(A)
Protection/Classification	
Enclosure class, motor	IP44
Insulation class	F
Data according to ErP	
ErP ready	ErP 2018
Dimensions and weights	
Duct dimension; Circular, inlet	250 mm
Duct dimension; Circular, outlet	250 mm
Weight	15.25 kg
Others	
Duct connection type	Circular
Motor type	AC

## Dimension



## Wiring

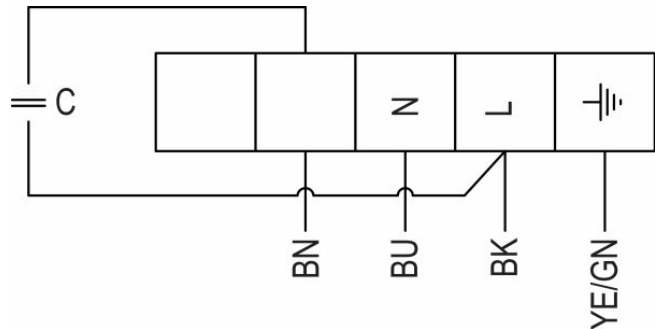

YE Yellow

BU Blue

GN Green

BN Brown

BK Black

## Performance curve

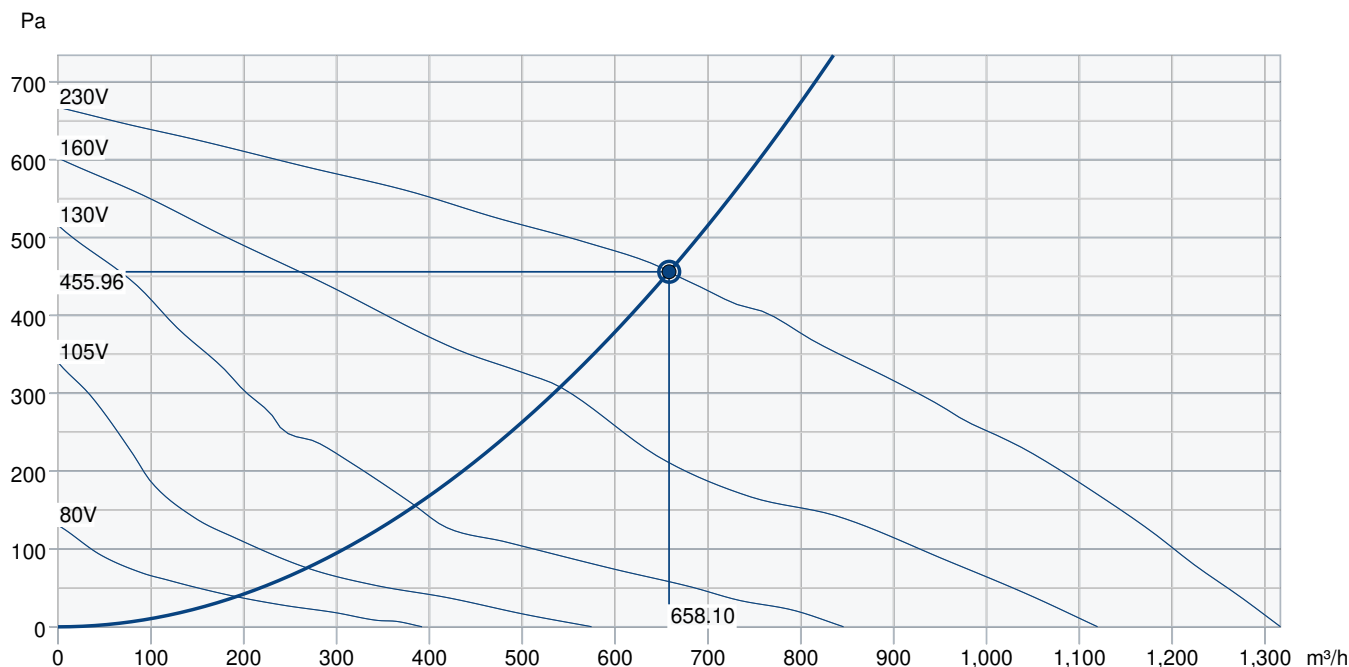

Hydraulic data										
Required air flow	658 m³/h									
Required static pressure	456 Pa									
Working air flow	658 m³/h									
Working static pressure	456 Pa									
Air density	1.204 kg/m³									
Power	225.4 W									
Fan control - RPM	2,728 rpm									
Current	1.00 A									
SFP	1.233 kW/m³/s									
Control voltage	230.0 V									
Supply voltage	230 V									
Sound power level		63	125	250	500	1k	2k	4k	8k	Total
Inlet	dB(A)	56	64	72	70	67	63	59	51	76
Outlet	dB(A)	54	61	69	64	63	64	56	47	72
Surrounding	dB(A)	37	48	58	57	53	50	48	36	62
Sound pressure level at 3m (20m² Sabine)	dB(A)	-	-	-	-	-	-	-	-	55
Sound pressure level at 3m free field	dB(A)	-	-	-	-	-	-	-	-	41
Accessories										

## Accessories

RE 1,5 Speed control (5000)

REU 1.5 Speed control (5004)

SG 250 Protection guard (5610)

CB 250-6,0 400V/2 Duct heater (5372)

Safety switch 2-pole grey (210679)

CB 250-9,0 400V/3 Duct heater (5373)

CBMF 250-3,0 230V/1 Duct heater (12248)

CWK 250-3-2,5 Duct cooler,circ (30024)

FGR 250 Filter cassette (1815)

LDC 250-900 Silencer (5196)

VBC 250-2 Water heating batt (5460)

VBF 250 Water heating battery (1733)

REE 2 Speed control (5316)

REV-3POL/03-7,5kW R/Y (33978)

VKK-250 Back draft damper (1627)

DTV500A (96807)

CB 250-3,0 230V/1 Duct heater (5385)

CBM 250-6,0 400V/2 Duct heater (9089)

CBMF 250-6,0 400V/2 Duct heater (12249)

FFR 250 Filter cassette (1776)

FK 250 Fast clamp (1612)

RSK-250 Back draft damper (5603)

VBC 250-3 Water heating batt (9843)

VK-25 Louvre shutter (5640)

## Documents

INSTALLATION\_OPERATION\_AND\_MAINTENANCE\_INSTRUCTION\_KV\_DUO\_KVK\_DUO\_KVK\_003\_EN.PDF

COMMISSIONING\_RECCORD\_FANS\_EN.PDF