

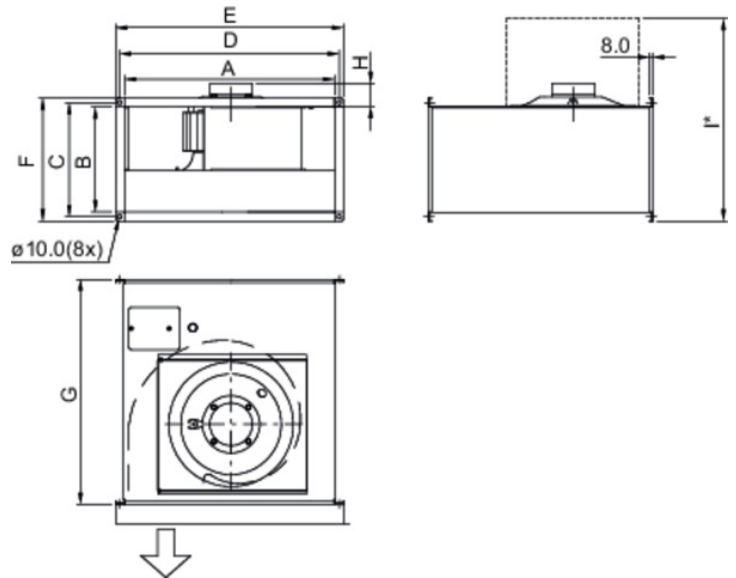

Technical parameters

Nominal data	
Voltage (nominal)	400 V
Frequency	50 Hz
Phases	3~
Input power	289 W
Input current	0.519 A
Impeller speed	1,303 rpm
Air flow	max 1,325 m ³ /h
Minimum static back pressure	0 Pa
Temperature of transported air	max 63 °C
Max temperature of transported air, when speed controlled	63 °C
Sound data	
Sound pressure level at 3m (20m ² Sabin)	52 dB(A)
Protection/Classification	
Enclosure class, motor	IP44
Insulation class	B
Data according to ErP	
ErP ready	ErP 2018
Dimensions and weights	
Duct dimension, inlet (height x width)	200 x 400 mm
Duct dimension, outlet (height x width)	200 x 400 mm
Weight	12.5 kg
Others	
Duct connection type	Rectangular
Motor type	AC

Dimension



	A	B	C	D	E	F	G	H	I'
KT 40-20	398	198	220	420	440	240	502	32	530
KT 50-25	498	248	270	520	540	290	532	68	610
KT 50-30	498	298	320	520	540	340	562	68	695
KT 60-30	598	298	320	620	640	340	642	89	715
KT 60-35	598	348	370	620	640	390	717	92	805
KT 70-40-4	698	398	420	720	740	440	787	92	900
KT 70-40-6/8	698	398	420	720	740	440	787	92	900
KT 80-50	798	497	520	820	840	540	880	113	1090
KT 100-50	998	497	520	1020	1040	540	980	113	1140

I' = Dimension with fully open hatch.

Wiring

400V 3~

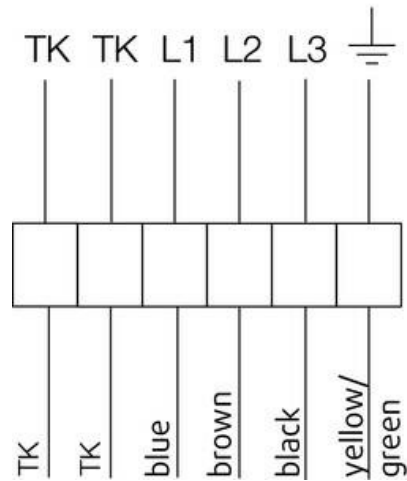

Performance curve

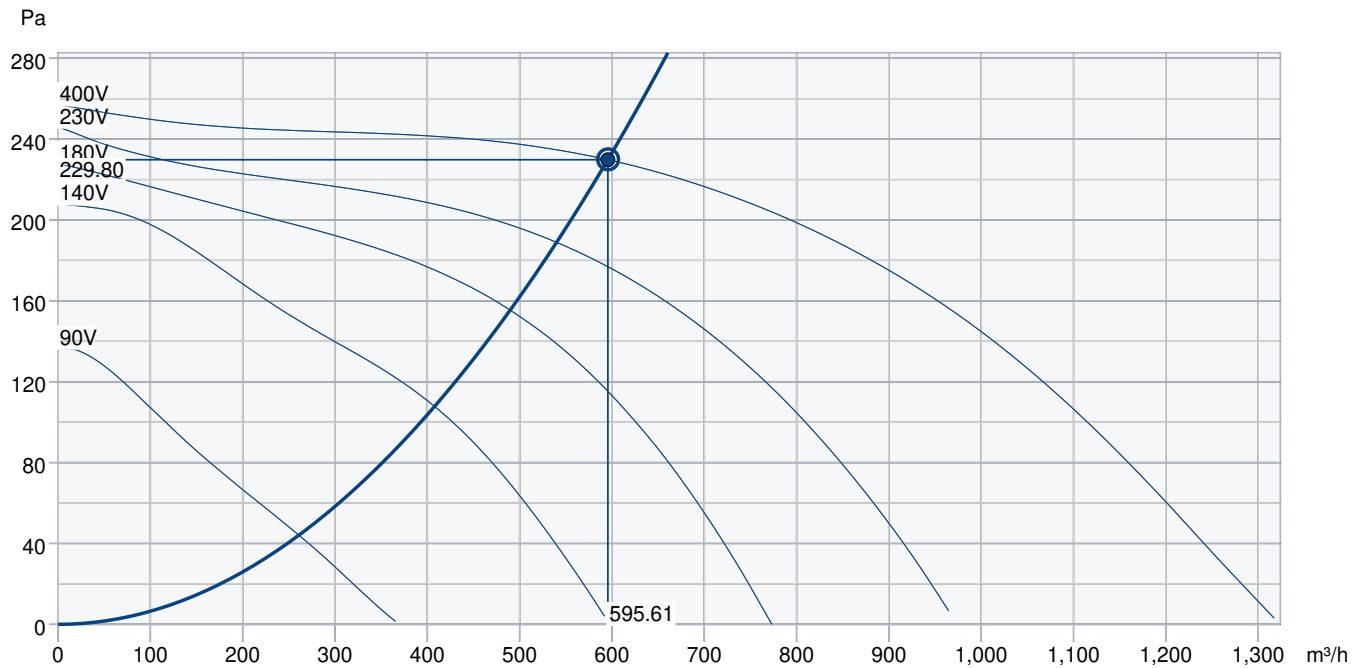

Hydraulic data

Required air flow	596 m³/h
Required static pressure	230 Pa
Working air flow	596 m³/h
Working static pressure	230 Pa
Air density	1.204 kg/m³
Power	126.2 W
Fan control - RPM	1,434 rpm
Current	0.40 A
SFP	0.763 kW/m³/s
Control voltage	400.0 V
Supply voltage	400 V

Sound power level		63	125	250	500	1k	2k	4k	8k	Total
Inlet	dB(A)	58	68	65	60	57	56	54	48	71
Outlet	dB(A)	55	64	68	64	66	63	60	54	73
Surrounding	dB(A)	35	47	58	52	50	45	41	36	60
Sound pressure level at 3m (20m² Sabine)	dB(A)	-	-	-	-	-	-	-	-	53
Sound pressure level at 3m free field	dB(A)	-	-	-	-	-	-	-	-	39

Accessories

Accessories

DS 40-20 Flexible connection (1539)
Frequency converter FRQS-4A (36231)
Motor protect. switch S-DT 16 (161206)
REV-5POL/07-7,5kW R/Y (33980)
RTRDU 2 Speed contr. Systemair (5945)
DTV500A (96807)
Presence detector/IR24-P (6995)
Safety switch 3-pole grey (210680)
VBR 40-20-4 Water heating batt (5471)
FFK 40-20 Filter cassette rect (1750)
PGK 40-20-3-2,0 Duct cooler (6604)
RB 40-20/9-1 400V/3 Duct heat. (9627)
VBR 40-20-2 Water heating batt (5463)
TUNE-S-400x200-M0 (420701)
TUNE-S-400x200-M5 (420706)

Frequency converter FRQ5S-4A (36233)
GFL 40-20 Counter flange (2705)
Motor protect. switch S-DT 16E (161207)
RTRD 2 Speed Cont. Systemair (5941)
CO2RT-R-D Transmitter (6993)
HR1 Room Humidistat (215150)
RT 0-30 Room Thermostat (5151)
T 120 Timer (5165)
DXRE 40-20-3-2,5 Duct cooler (7951)
LDR 40-20 Silencer (5069)
RB 40-20/15-1 400V/3 Duct heat (9628)
RBM 40-20/9 400V/3 Duct heater (5450)
Room hygrostat HR-S (286251)
TUNE-S-400x200-M4 (420705)

Documents

INSTALLATION_OPERATION_AND_MAINTENANCE_INSTRUCTION_KE_KT_RS_RSI_EN_002.PDF
COMMISSIONING_RECORD_FANS_EN.PDF