



KBT Centrifugal Fans

Powerful and efficient exhaust fans for medium temperatures up to 120°C

- Up to 120°C medium temperature, continuous operation
- Acoustic and thermal insulation 50 mm
- Excellent for commercial kitchens and process exhaust systems
- Easy to service and maintain due to the swing-out inspection door and drain plug

[Find more details in our online catalogue](#)

Reliability

The KBT fans are designed for reliable, continuous use with medium temperatures up to 120°C.

The combination of reliable casing and motor construction ensure to minimize the need for maintenance of the fans and allows long **continuous operation**.

High performance

High performance impeller together with **high efficient** motor are designed to ensure high-level performance with **minimum power consumption** and **maximum efficiency**.

Low noise

Casing of KBT models have perfect **acoustic/thermal insulation** capacity. In addition, **anti-vibration** dampers and **flexible connections** allows to reduce noise and vibration transfer to the duct system.

Easy maintenance

Integrated protection plate prevents escaping grease or oil. Integrated **drain plug** for liquids allows to organise a natural drain. A dedicated **swing-out maintenance door** allows quick and easy maintenance of the fan.

Certifications



Green Ventilation

Features

Construction

The KBT casing is manufactured from **doubleskinned galvanised sheet steel** and is insulated with **50 mm mineral wool**.

The fan motor is mounted on a **swing-out door outside of the airstream** and covered by **weather protection**.

Casing design includes **integrated protection plate** to prevent escaping grease or oil and integrated **drain plug** for draining liquids.

Impeller

The KBT fans use lightweight **radial** impellers with **forward curved blades**. These are manufactured from galvanised steel, dynamically **balanced** and paired with corresponding motor.

Motor

Depends on type, KBT fans are equipped with **IEC motors** (efficiency class IE3) or **EC motor**.

Models with **EC motors** are suitable for operation at **50Hz** and **60Hz**.

Motor protection

Models with **AC** motors have integrated **thermal contacts TK** or integrated **thermistors PTC** with leads for connection to an external motor protection device.

Models with **EC** motors have **integrated** electronic **thermal protection** including **locked-rotor protection** and **soft-start**.

Control

Models with **AC motor** can be controlled by **frequency converter**.

Models with **EC motor** equipped with **built-in potentiometer** to adjust working point, can be controlled by external **signal 0-10V**.

Installation

KBT fans can be used **indoor** or **outdoor**. Due to the integrated **base frame** the fan can stand **on the floor** or on the **wall mounting brackets**.

Base frame equipped with **anti-vibration dampers** to prevent vibration transfer from the fan to the construction elements. For **preventing vibration** to the ducts it is recommended to use **flexible connections**.

Technical parameters

Nominal data

Voltage (nominal)	400	V
Frequency	50	Hz
Phases	3~	
Motor circuit connection	Y	
Input power	863	W
Input power kW	0.863	kW
Input current	1.68	A
Impeller speed	1,445	rpm
Air flow	max 2,651	m³/h
Temperature of transported air	max 120	°C

Sound data

Sound pressure level at 4m (free field)	36	dB
---	----	----

Protection/Classification

Insulation class	F
------------------	---

Data according to ErP

ErP ready	Not ErP relevant
-----------	------------------

Dimensions and weights

Duct dimension; Circular, inlet	225	mm
Weight	39	kg

Others

Motor type	AC
------------	----

Performance

Performance curve

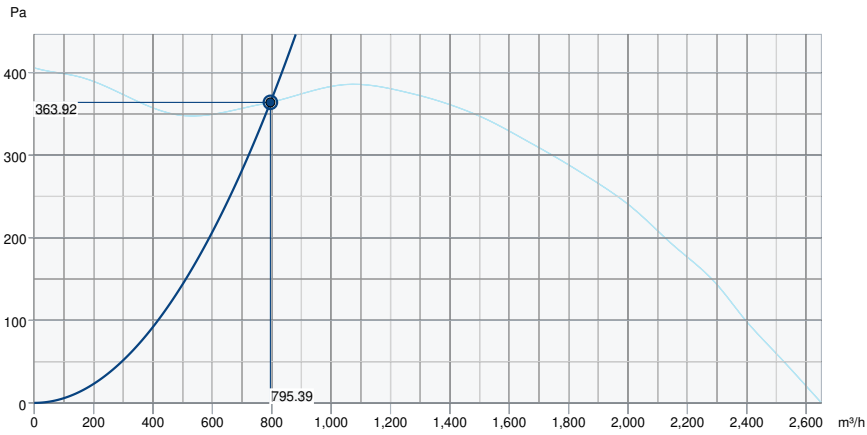

Hydraulic data

Required air flow	795 m³/h
Required static pressure	364 Pa
Working air flow	795 m³/h
Working static pressure	364 Pa
Air density	1.204 kg/m³
Power	160.9 W
Fan control - RPM	1,482 rpm
Current	0.99 A
SFP	0.728 kW/m³/s
Control voltage	400.0 V
Supply voltage	400 V

Sound power level		63	125	250	500	1k	2k	4k	8k	Total
Inlet	dB(A)	62	66	63	65	67	65	63	59	73
Outlet	dB(A)	60	62	66	69	68	65	62	57	74
Surrounding	dB(A)	22	43	42	51	48	57	42	38	59
Sound pressure level at 3m (20m² Sabine)	dB(A)	-	-	-	-	-	-	-	-	52
Sound pressure level at 3m free field	dB(A)	-	-	-	-	-	-	-	-	38

Dimension

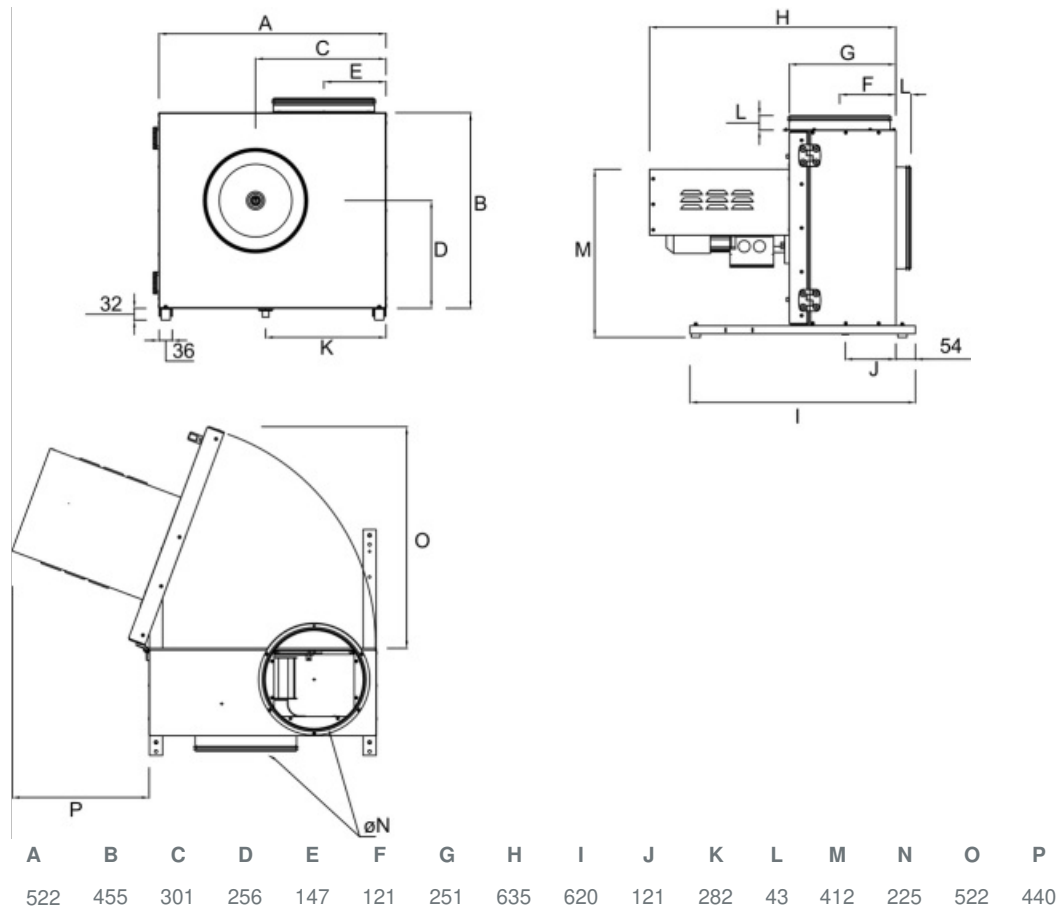

Wiring

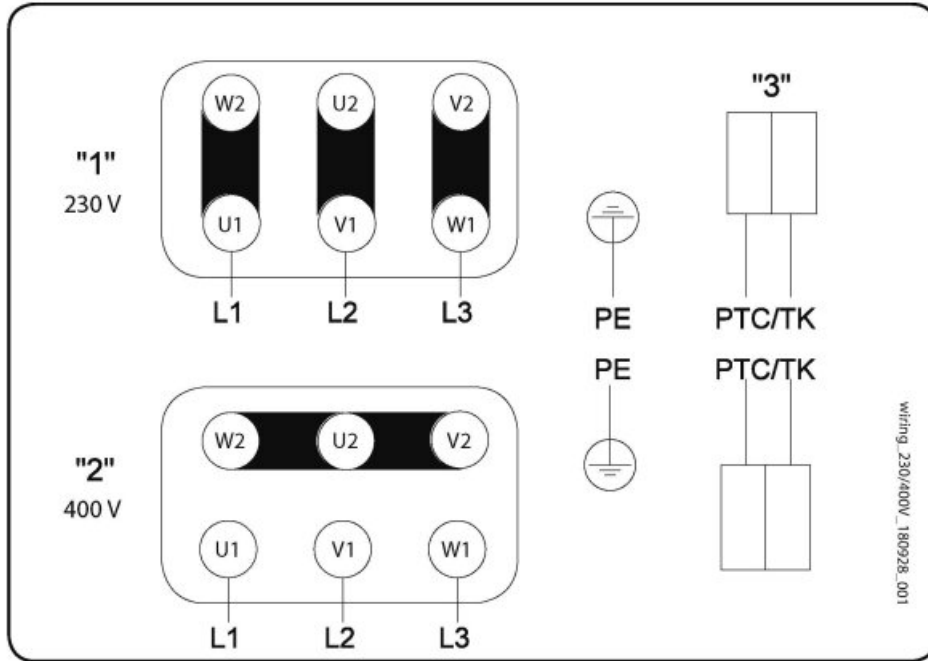

- 1 3 x 230V Delta Connection
 - 2 3 x 400V Star connection
 - 3 PTC / TK
- Changing of direction of rotation by interchanging of two phases

Accessories

- Frequency converter FRQ-4A (36227)
- REV-5POL/05-7,5kW R/Y (33979)
- U-EK230E Motor protection (30199)
- REV-5POL/07-EMV-7,5kW R/Y (34549)
- ASF 225/KB Flex. connection (2715)
- Frequency converter FRQS-4A (36231)
- REV-9POL/12-7,5kW R/Y (33981)
- MF 224 (210393)
- Safety switch 3-pole grey (210680)
- KBT 225/250/280 Wall bracket (182813)

Documents

- INSTALLATION__OPERATION_AND_MAINTENANCE_INSTRUCTION_KBT__EN_005.PDF
- COMMISSIONING_RECORD_FANS__EN.PDF