

Bend

BSTR 45°

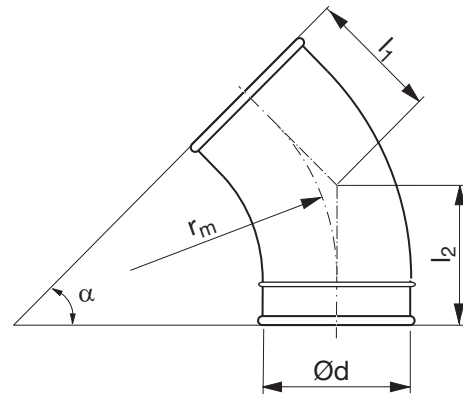

Dimensions



$$r_m \approx 1,5 \cdot d$$

Description

Pressed and seam welded bend.

Ød nom	t mm	r _m mm	l ₁ mm	l ₂ mm	m kg
100 *	0,6	150	92	118	0,30
125 *	0,7	190	109	135	0,40
150 *	0,7	225	123	149	0,50
160 *	0,7	240	129	155	0,60
180 *	0,7	270	137	164	0,90
200 **	0,6	300	176	176	0,88

* 1 swaged-on end

** 2 swaged-on ends

Ordering example

